

TYPICAL QUESTIONS & ANSWERS

PART- I

OBJECTIVE TYPE QUESTIONS

Each Question carries 2 marks.

Choose the correct or best alternative in the following:

- Q.1** The discrete-time signal $x(n] = (-1)^n$ is periodic with fundamental period
 (A) 6 (B) 4
 (C) 2 (D) 0

Ans: C Period = 2

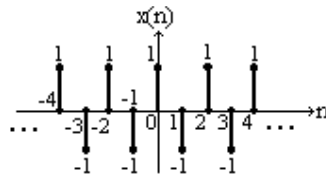

- Q.2** The frequency of a continuous time signal $x(t)$ changes on transformation from $x(t)$ to $x(\alpha t)$, $\alpha > 0$ by a factor
 (A) α . (B) $\frac{1}{\alpha}$.
 (C) α^2 . (D) $\sqrt{\alpha}$.

Ans: A $x(t) \xrightarrow{\text{Transform}} x(\alpha t), \alpha > 0$
 $\alpha > 1 \implies$ compression in t, expansion in f by α .
 $\alpha < 1 \implies$ expansion in t, compression in f by α .

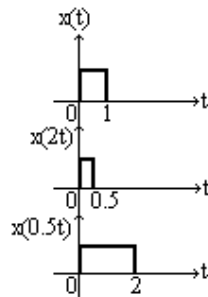

- Q.3** A useful property of the unit impulse $\delta(t)$ is that
 (A) $\delta(at) = a \delta(t)$. (B) $\delta(at) = \delta(t)$.
 (C) $\delta(at) = \frac{1}{a} \delta(t)$. (D) $\delta(at) = [\delta(t)]^a$.

Ans: C Time-scaling property of $\delta(t)$:
 $\delta(at) = \frac{1}{a} \delta(t), a > 0$

- Q.4** The continuous time version of the unit impulse $\delta(t)$ is defined by the pair of relations

- (A) $\delta(t) = \begin{cases} 1 & t = 0 \\ 0 & t \neq 0 \end{cases}$ (B) $\delta(t) = 1, t = 0$ and $\int_{-\infty}^{\infty} \delta(t) dt = 1$.
- (C) $\delta(t) = 0, t \neq 0$ and $\int_{-\infty}^{\infty} \delta(t) dt = 1$. (D) $\delta(t) = \begin{cases} 1, & t \geq 0 \\ 0, & t < 0 \end{cases}$.

Ans: C $\delta(t) = 0, t \neq 0 \rightarrow \delta(t) \neq 0$ at origin
 $\int_{-\infty}^{+\infty} \delta(t) dt = 1 \rightarrow$ Total area under the curve is unity.
 [-∞] $\delta(t)$ is also called Dirac-delta function]

- Q.5** Two sequences $x_1(n)$ and $x_2(n)$ are related by $x_2(n) = x_1(-n)$. In the z - domain, their ROC's are
 (A) the same. (B) reciprocal of each other.
 (C) negative of each other. (D) complements of each other.

Ans: B $x_1(n) \xleftrightarrow{z} X_1(z), \text{RoC } R_x$ }
 $x_2(n) = x_1(-n) \xleftrightarrow{z} X_1(1/z), \text{RoC } 1/R_x$ } Reciprocals

- Q.6** The Fourier transform of the exponential signal $e^{j\omega_0 t}$ is
 (A) a constant. (B) a rectangular gate.
 (C) an impulse. (D) a series of impulses.

Ans: C Since the signal contains only a high frequency ω_0 its FT must be an impulse at $\omega = \omega_0$

- Q.7** If the Laplace transform of $f(t)$ is $\frac{\omega}{(s^2 + \omega^2)}$, then the value of $\lim_{t \rightarrow \infty} f(t)$
 (A) cannot be determined. (B) is zero.
 (C) is unity. (D) is infinity.

Ans: B $f(t) \xleftrightarrow{L} \frac{\omega}{s^2 + \omega^2}$

$$\lim_{t \rightarrow \infty} f(t) = \lim_{s \rightarrow 0} s F(s) \quad \text{[Final value theorem]}$$

$$= \lim_{s \rightarrow 0} \left[\frac{s\omega}{s^2 + \omega^2} \right] = 0$$

- Q.8** The unit impulse response of a linear time invariant system is the unit step function $u(t)$. For $t > 0$, the response of the system to an excitation $e^{-at}u(t)$, $a > 0$, will be

- (A) ae^{-at} . (B) $\frac{1 - e^{-at}}{a}$.

(C) $a(1 - e^{-at})$.

(D) $1 - e^{-at}$.

Ans: B

$h(t) = u(t); \quad x(t) = e^{-at} u(t), \quad a > 0$

$$\begin{aligned} \text{System response } y(t) &= L^{-1} \left[\frac{1}{s} \cdot \frac{1}{s+a} \right] \\ &= L^{-1} \frac{1}{a} \left[\frac{1}{s} - \frac{1}{s+a} \right] \\ &= \frac{1}{a} (1 - e^{-at}) \end{aligned}$$

Q.9 The z-transform of the function $\sum_{k=-\infty}^0 \delta(n-k)$ has the following region of convergence

(A) $|z| > 1$

(B) $|z| = 1$

(C) $|z| < 1$

(D) $0 < |z| < 1$

Ans: C $x(n) = \sum_{k=-\infty}^0 \delta(n-k)$

$$\begin{aligned} x(z) &= \sum_{k=-\infty}^0 z^{-k} = \dots + z^3 + z^2 + z + 1 \quad (\text{Sum of infinite geometric series}) \\ &= \frac{1}{1-z}, \quad |z| < 1 \end{aligned}$$

Q.10 The auto-correlation function of a rectangular pulse of duration T is

- (A) a rectangular pulse of duration T.
- (B) a rectangular pulse of duration 2T.
- (C) a triangular pulse of duration T.
- (D) a triangular pulse of duration 2T.

Ans: D

$$R_{XX}(\tau) = \frac{1}{T} \int_{-T/2}^{T/2} x(\tau) x(t + \tau) d\tau \Rightarrow \text{triangular function of duration } 2T.$$

Q.11 The Fourier transform (FT) of a function $x(t)$ is $X(f)$. The FT of $dx(t)/dt$ will be

- (A) $dX(f)/df$.
- (B) $j2\pi f X(f)$.
- (C) $jf X(f)$.
- (D) $X(f)/(jf)$.

Ans: B $x(t) = \frac{1}{2\pi} \int_{-\infty}^{\infty} X(f) e^{j\omega t} d\omega$

$$\begin{aligned} \frac{d_x}{dt} &= \frac{1}{2\pi} \int_{-\infty}^{\infty} j\omega X(f) e^{j\omega t} d\omega \\ \therefore \frac{d_x}{dt} &\leftrightarrow j 2\pi f X(f) \end{aligned}$$

Q.12 The FT of a rectangular pulse existing between $t = -T/2$ to $t = T/2$ is a

- (A) sinc squared function.
- (B) sinc function.
- (C) sine squared function.
- (D) sine function.

Ans: B $x(t) = \begin{cases} 1, & -\frac{T}{2} \leq t \leq \frac{T}{2} \\ 0, & \text{otherwise} \end{cases}$

$$X(j\omega) = \int_{-\infty}^{+\infty} x(t) e^{-j\omega t} dt = \int_{-T/2}^{+T/2} e^{-j\omega t} dt = \frac{e^{-j\omega t}}{-j\omega} \Bigg|_{-T/2}^{+T/2}$$

$$= -\frac{1}{j\omega} (e^{-j\omega T/2} - e^{j\omega T/2}) = \frac{2}{\omega} \left(\frac{e^{j\omega T/2} - e^{-j\omega T/2}}{2j} \right)$$

$$= \frac{2 \sin \omega T}{\omega} = \frac{\sin(\omega T/2)}{\omega T/2} \cdot T$$

Hence $X(j\omega)$ is expressed in terms of a sinc function.

Q.13 An analog signal has the spectrum shown in Fig. The minimum sampling rate needed to completely represent this signal is

- (A) 3 KHz .
- (B) 2 KHz .
- (C) 1 KHz .
- (D) 0.5 KHz .

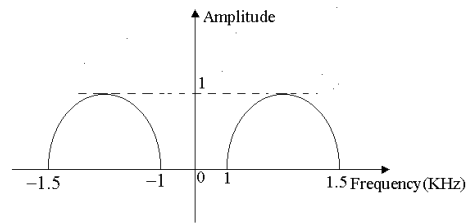

Ans: C For a band pass signal, the minimum sampling rate is twice the bandwidth, which is 0.5 kHz here.

Q.14 A given system is characterized by the differential equation:

$$\frac{d^2y(t)}{dt^2} - \frac{dy(t)}{dt} - 2y(t) = x(t).$$

The system is:

- (A) linear and unstable.
- (B) linear and stable.
- (C) nonlinear and unstable.
- (D) nonlinear and stable.

Ans:A $\frac{d^2y(t)}{dt^2} - \frac{dy(t)}{dt} - 2y(t) = x(t)$, $x(t) \rightarrow \boxed{\text{system } h(t)} \rightarrow y(t)$

The system is linear . Taking LT with zero initial conditions, we get $s^2Y(s) - sY(s) - 2Y(s) = X(s)$

$$\text{or, } H(s) = \frac{Y(s)}{X(s)} = \frac{1}{s^2 - s - 2} = \frac{1}{(s - 2)(s + 1)}$$

Because of the pole at $s = +2$, the system is unstable.

Q.15 The system characterized by the equation $y(t) = ax(t) + b$ is

- (A) linear for any value of b.
- (B) linear if $b > 0$.
- (C) linear if $b < 0$.
- (D) non-linear.

Ans: D The system is non-linear because $x(t) = 0$ does not lead to $y(t) = 0$, which is a violation of the principle of homogeneity.

Q.16 Inverse Fourier transform of $u(\omega)$ is

- (A) $\frac{1}{2} \delta(t) + \frac{1}{\pi t}$.
- (B) $\frac{1}{2} \delta(t)$.
- (C) $2\delta(t) + \frac{1}{\pi t}$.
- (D) $\delta(t) + \text{sgn}(t)$.

Ans: A $x(t) = u(t) \xleftrightarrow{\text{FT}} X(j\omega) = \pi \frac{\delta(\omega)}{j\omega} + 1$

Duality property: $X(jt) \longleftrightarrow 2\pi x(-\omega)$

$u(\omega) \longleftrightarrow \frac{1}{2} \delta(t) + \frac{1}{\pi t}$

Q.17 The impulse response of a system is $h(n) = a^n u(n)$. The condition for the system to be BIBO stable is

- (A) a is real and positive.
- (B) a is real and negative.
- (C) $|a| > 1$.
- (D) $|a| < 1$.

Ans: D Sum $S = \sum_{n=-\infty}^{+\infty} |h(n)| = \sum_{n=-\infty}^{+\infty} |a^n u(n)|$
 $\leq \sum_{n=0}^{+\infty} |a|^n$ ($\because u(n) = 1$ for $n \geq 0$)
 $\leq \frac{1}{1 - |a|}$ if $|a| < 1$.

Q.18 If R_1 is the region of convergence of $x(n)$ and R_2 is the region of convergence of $y(n)$, then the region of convergence of $x(n)$ convoluted $y(n)$ is

- (A) $R_1 + R_2$.
- (B) $R_1 - R_2$.
- (C) $R_1 \cap R_2$.
- (D) $R_1 \cup R_2$.

Ans: C $x(n) \xleftrightarrow{z} X(z), \text{ RoC } R_1$
 $y(n) \xleftrightarrow{z} Y(z), \text{ RoC } R_2$
 $x(n) * y(n) \xleftrightarrow{z} X(z) \cdot Y(z), \text{ RoC at least } R_1 \cap R_2$

Q.19 The continuous time system described by $y(t) = x(t^2)$ is

- (A) causal, linear and time varying.
- (B) causal, non-linear and time varying.
- (C) non causal, non-linear and time-invariant.
- (D) non causal, linear and time-invariant.

Ans: D

$$y(t) = x(t^2)$$

$y(t)$ depends on $x(t^2)$ i.e., future values of input if $t > 1$.

∴ System is anticipative or non-causal

$$\alpha x_1(t) \rightarrow y_1(t) = \alpha x_1(t^2)$$

$$\beta x_2(t) \rightarrow y_2(t) = \beta x_2(t^2)$$

$$\therefore \alpha x_1(t) + \beta x_2(t) \rightarrow y(t) = \alpha x_1(t^2) + \beta x_2(t^2) = y_1(t) + y_2(t)$$

∴ System is Linear

System is time varying. Check with $x(t) = u(t) - u(t-z) \rightarrow y(t)$ and

$$x_1(t) = x(t-1) \rightarrow y_1(t) \text{ and find that } y_1(t) \neq y(t-1).$$

Q.20 If $G(f)$ represents the Fourier Transform of a signal $g(t)$ which is real and odd symmetric in time, then $G(f)$ is

- (A) complex.
- (B) imaginary.
- (C) real.
- (D) real and non-negative.

FT

Ans: B $g(t) \longleftrightarrow G(f)$

$g(t)$ real, odd symmetric in time

$$G^*(j\omega) = -G(j\omega); G(j\omega) \text{ purely imaginary.}$$

Q.21 For a random variable x having the PDF shown in the Fig., the mean and the variance are, respectively,

- (A) $\frac{1}{2}$ and $\frac{2}{3}$.
- (B) 1 and $\frac{4}{3}$.
- (C) 1 and $\frac{2}{3}$.
- (D) 2 and $\frac{4}{3}$.

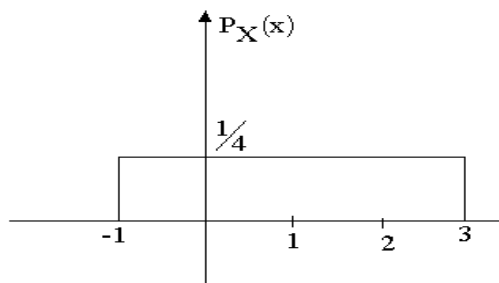

Ans: B Mean = $\mu_x(t) = \int_{-\infty}^{+\infty} x f_{x(t)}(x) dx$

$$= \int_{-1}^3 x \frac{1}{4} dx = \frac{1}{4} \left. \frac{x^2}{2} \right|_{-1}^3 = \left(\frac{9}{2} - \frac{1}{2} \right) \frac{1}{4} = 1$$

Variance = $\int_{-\infty}^{+\infty} (x - \mu_x)^2 f_x(x) dx$

$$= \int_{-1}^3 (x-1)^2 \frac{1}{4} d(x-1)$$

- (A) the constant term will be zero.
- (B) there will be no cosine terms.
- (C) there will be no sine terms.
- (D) there will be no even harmonics.

Ans:

$$\frac{1}{T} \int_0^T f(t) dt = \frac{1}{T} \left(\int_0^{T/2} f(t) dt + \int_{T/2}^T f(t) dt \right) = \frac{1}{T} \left(\int_0^{T/2} f(t) dt + \int_0^{T/2} f(\tau + T/2) d\tau \right) = 0$$

- Q.27** A band pass signal extends from 1 KHz to 2 KHz. The minimum sampling frequency needed to retain all information in the sampled signal is
- (A) 1 KHz.
 - (B) 2 KHz.
 - (C) 3 KHz.
 - (D) 4 KHz.

Ans: B

Minimum sampling frequency = 2(Bandwidth) = 2(1) = 2 kHz

- Q.28** The region of convergence of the z-transform of the signal $2^n u(n) - 3^n u(-n - 1)$
- (A) is $|z| > 1$.
 - (B) is $|z| < 1$.
 - (C) is $2 < |z| < 3$.
 - (D) does not exist.

Ans:

$$2^n u(n) \longleftrightarrow \frac{1}{1 - 2z^{-1}}, |z| > 2$$

$$3^n u(-n-1) \longleftrightarrow \frac{1}{1 - 3z^{-1}}, |z| < 3$$

∴ ROC is $2 < |z| < 3$.

- Q.29** The number of possible regions of convergence of the function $\frac{(e^{-2} - 2)z}{(z - e^{-2})(z - 2)}$ is
- (A) 1.
 - (B) 2.
 - (C) 3.
 - (D) 4.

Ans: C

Possible ROC's are $|z| > e^{-2}$, $|z| < 2$ and $e^{-2} < |z| < 2$

- Q.30** The Laplace transform of $u(t)$ is $A(s)$ and the Fourier transform of $u(t)$ is $B(j\omega)$. Then

- (A) $B(j\omega) = A(s)|_{s=j\omega}$.
- (B) $A(s) = \frac{1}{s}$ but $B(j\omega) \neq \frac{1}{j\omega}$.
- (C) $A(s) \neq \frac{1}{s}$ but $B(j\omega) = \frac{1}{j\omega}$.
- (D) $A(s) \neq \frac{1}{s}$ but $B(j\omega) \neq \frac{1}{j\omega}$.

Ans: B $u(t) \xleftrightarrow{L} A(s) = \frac{1}{s}$

$$\text{F.T} \\ u(t) \xleftrightarrow{\quad} B(j\omega) = \frac{1}{j\omega} + \pi \delta(\omega)$$

$$\therefore A(s) = \frac{1}{s} \text{ but } B(j\omega) \neq \frac{1}{j\omega}$$

- Q.31** Given a unit step function $u(t)$, its time-derivative is:
 (A) a unit impulse. (B) another step function.
 (C) a unit ramp function. (D) a sine function.

Ans: A

- Q.32** The impulse response of a system described by the differential equation $\frac{d^2y}{dt^2} + y(t) = x(t)$ will be
 (A) a constant. (B) an impulse function.
 (C) a sinusoid. (D) an exponentially decaying function.

Ans: C

- Q.33** The function $\frac{\sin(\pi u)}{(\pi u)}$ is denoted by:
 (A) $\sin c(\pi u)$. (B) $\sin c(u)$.
 (C) signum. (D) none of these.

Ans: C

- Q.34** The frequency response of a system with $h(n) = \delta(n) - \delta(n-1)$ is given by
 (A) $\delta(\omega) - \delta(\omega - 1)$. (B) $1 - e^{j\omega}$.
 (C) $u(\omega) - u(\omega - 1)$. (D) $1 - e^{-j\omega}$.

Ans: D

- Q.35** The order of a linear constant-coefficient differential equation representing a system refers to the number of
 (A) active devices. (B) elements including sources.
 (C) passive devices. (D) none of those.

Ans: D

- Q.36** z-transform converts convolution of time-signals to
 (A) addition. (B) subtraction.
 (C) multiplication. (D) division.

Ans: C

- Q.37** Region of convergence of a causal LTI system
 (A) is the entire s-plane. (B) is the right-half of s-plane.
 (C) is the left-half of s-plane. (D) does not exist.

Ans: B

- Q.38** The DFT of a signal $x(n)$ of length N is $X(k)$. When $X(k)$ is given and $x(n)$ is computed from it, the length of $x(n)$
- (A) is increased to infinity (B) remains N
 (C) becomes $2N - 1$ (D) becomes N^2

Ans: A

- Q.39** The Fourier transform of $u(t)$ is
- (A) $\frac{1}{j2\pi f}$ (B) $j2\pi f$.
 (C) $\frac{1}{1 + j2\pi f}$ (D) none of these.

Ans: D

- Q.40** For the probability density function of a random variable X given by $f_x(x) = 5e^{-Kx}u(x)$, where $u(x)$ is the unit step function, the value of K is
- (A) $\frac{1}{5}$ (B) $\frac{1}{25}$
 (C) 25 (D) 5

Ans: D

- Q.41** The system having input $x(n)$ related to output $y(n)$ as $y(n) = \log_{10}|x(n)|$ is:
- (A) nonlinear, causal, stable. (B) linear, noncausal, stable.
 (C) nonlinear, causal, not stable. (D) linear, noncausal, not stable.

Ans: A

- Q.42** To obtain $x(4 - 2n)$ from the given signal $x(n)$, the following precedence (or priority) rule is used for operations on the independent variable n :
- (A) Time scaling \rightarrow Time shifting \rightarrow Reflection.
 (B) Reflection \rightarrow Time scaling \rightarrow Time shifting.
 (C) Time scaling \rightarrow Reflection \rightarrow Time shifting.
 (D) Time shifting \rightarrow Time scaling \rightarrow Reflection.

Ans: D

- Q.43** The unit step-response of a system with impulse response $h(n) = \delta(n) - \delta(n - 1)$ is:
- (A) $\delta(n - 1)$. (B) $\delta(n)$.
 (C) $u(n - 1)$. (D) $u(n)$.

Ans: B

Ans (B) $x[n] = \begin{cases} 1, & n \leq N \\ 0, & \text{otherwise} \end{cases}$

Here the function $u(-n)$ is delayed by N units.

Q.50 A continuous-time periodic signal $x(t)$, having a period T , is convolved with itself. The resulting signal is

- (A) not periodic (B) periodic having a period T
 (C) periodic having a period $2T$ (D) periodic having a period $T/2$

Ans (B) periodic having a period T
 Convolution of a periodic signal (period T) with itself will give the same period T .

Q.51 If the Fourier series coefficients of a signal are periodic then the signal must be

- (A) continuous-time, periodic (B) discrete-time, periodic
 (C) continuous-time, non-periodic (D) discrete-time, non-periodic

Ans (B) discrete-time, periodic
 This is the property of the discrete-time periodic signal.

Q.52 The Fourier transform of a signal $x(t) = e^{2t}u(-t)$ is given by

- (A) $\frac{1}{2 - j\omega}$ (B) $\frac{2}{1 - j\omega}$
 (C) $\frac{1}{j2 - \omega}$ (D) $\frac{2}{j2 - \omega}$

Ans (A) $\frac{1}{2 - j\omega}$

FT $u(t) = \frac{1}{j\omega}$. Therefore, FT of $u(-t) = \frac{1}{-j\omega}$. If a function $x(t)$ is multiplied by e^{2t} , then its FT will be $F(j\omega)|_{j\omega \rightarrow j\omega - 2}$. Hence the answer.

Q.53 For the function $H(j\omega) = \frac{1}{2 + 2j\omega + (j\omega)^2}$, maximum value of group delay is

- (A) 1 (B) 1/2
 (C) 2 (D) 3

Ans None of the given answers is correct.

Q.54 A continuous-time signal $x(t)$ is sampled using an impulse train. If $X(j\omega)$ is the Fourier transform of $x(t)$, the spectrum of the sampled signal can be expressed as

- (A) $\sum_{k=-\infty}^{\infty} X(j\omega + k\omega_s)\delta(\omega)$ (B) $\sum_{k=-\infty}^{\infty} X(jk\omega) * \delta(\omega + k\omega_s)$
 (C) $\sum_{k=-\infty}^{\infty} X(j\omega) * \delta(\omega + k\omega_s)$ (D) $\sum_{k=-\infty}^{\infty} X(j\omega)\delta(\omega + k\omega_s)$

Ans (A) $\sum_{k=-\infty}^{\infty} X(j\omega + k\omega_s) \delta(\omega)$

Since the spectrum consists of various harmonics $k = -\infty$ to ∞ and discretely spread at an interval of fundamental frequency f_s . Hence the answer.

Q.55 The region of convergence of a causal finite duration discrete-time signal is

- (A) the entire z -plane except $z = 0$
- (B) the entire z -plane except $z = \infty$
- (C) the entire z -plane
- (D) a strip in z -plane enclosing $j\omega$ -axis

Ans (A) The entire z -plane except $z = 0$

$X(z) = \sum_{n=n_1}^{n_2} x[n]z^{-n}$. This sum should converge provided each term in the sum is

finite. However, if there is a non-zero causal component for $n_2 > 0$, then $X(z)$ will have a term involving z^{-1} and thus ROC cannot include $z = 0$.

Q.56 Let $H(e^{j\omega})$ be the frequency response of a discrete-time LTI system, and $H_1(e^{j\omega})$ be the frequency response of its inverse. Then,

- (A) $H(e^{j\omega})H_1(e^{j\omega}) = 1$
- (B) $H(e^{j\omega})H_1(e^{j\omega}) = \delta(\omega)$
- (C) $H(e^{j\omega}) * H_1(e^{j\omega}) = 1$
- (D) $H(e^{j\omega}) * H_1(e^{j\omega}) = \delta(\omega)$

Ans (A) $H(e^{j\omega})H_1(e^{j\omega}) = 1$

Since $H(e^{j\omega})$ and $H_1(e^{j\omega})$ are the inverse of each other, their product should equal 1.

Q.57 The transfer function of a stable system is $H(z) = \frac{1}{1 - 0.5z^{-1}} + \frac{1}{1 - 2z^{-1}}$.

Its impulse response will be

- (A) $(0.5)^n u[n] + (2)^n u[n]$
- (B) $-(0.5)^n u[-n - 1] + (2)^n u[n]$
- (C) $(0.5)^n u[n] - (2)^n u[-n - 1]$
- (D) $-(0.5)^n u[-n - 1] - (2)^n u[-n - 1]$

Ans (C) $(0.5)^n u[n] - (2)^n u[-n - 1]$

(A) and (C) are the possible IFTs of the given system function. However, the system is stable; therefore (C) is the only correct answer.

Q.58 The probability cumulative distribution function must be monotone and

- (A) increasing
- (B) decreasing
- (C) non-increasing
- (D) non-decreasing

Ans (D) non-decreasing

The probability cumulative distribution function increases to 1 monotonically and there after remains constant.

Q.59 The average power of the following signal is

Ans: (D) Here the highest frequency present in the signal is $\omega_m = 300\pi$ or $f_m = 150$ Hz. Therefore the Nyquist frequency $f_s = 2f_m = 300$ Hz.

Q.64 The step response of a LTI system when the impulse response $h(n)$ is unit step $u(n)$ is

- (A) $n+1$ (B) n
(C) $n-1$ (D) n^2

Ans: (A)

$$y(n) = x(n) * h(n) = u(n) * u(n) = \sum_{k=-\infty}^{\infty} u(k)u(n-k) = \sum_{k=0}^n u(k)u(n-k)$$

$$y(0) = 1, y(1) = 2, y(2) = 3, \dots, y(n) = (n+1)$$

$$y(n) = (n+1).$$

Q.65 The Laplace transform of $u(t)$ is

- (A) $\frac{1}{s}$ (B) s^2
(C) $\frac{1}{s^2}$ (D) s

Ans: (A)

Substituting $f(t) = u(t)$ in the relation $F(s) = \int_0^{\infty} f(t)e^{-st} dt$ gives the answer.

Q.66 The function which has its Fourier transform, Laplace transform, and Z transform unity is

- (A) Gaussian (B) impulse
(C) Sinc (D) pulse

Ans: (B)

Substituting $f(t) = \delta(t)$ in the definitions of Fourier, Laplace and Z-transform, we get the transforms in each case as 1.

Q.67 The Z transform of $\delta(n-m)$ is

- (A) z^{-n} (B) z^{-m}
(C) $\frac{1}{z-n}$ (D) $\frac{1}{z-m}$

Ans: (B)

The Z-transform of a delayed function $f(n-m)$ is z^{-m} times the Z-transform of the function $f(n)$.

Q.68 If the joint probability pdf of $f(x, y) = \frac{1}{4}$, $0 \leq x, y \leq 2$, $P(x+y \leq 1)$ is

- (A) $\frac{1}{8}$ (B) $\frac{1}{16}$
(C) $\frac{1}{4}$ (D) $\frac{1}{2}$

Ans: (A)

$$P(x + y) = \int_0^1 \int_0^{1-y} \frac{1}{4} dx dy = \frac{1}{4} \int_0^1 x \Big|_0^{1-y} dy = \frac{1}{4} \int_0^1 (1-y) dy = \frac{1}{8}.$$

Q.69 The period of the signal $x(t) = 10 \sin 12\pi t + 4 \cos 18\pi t$ is

- (A) $\frac{\pi}{4}$ (B) $\frac{1}{6}$
- (C) $\frac{1}{9}$ (D) $\frac{1}{3}$

Ans: (D)

There are two waveforms of frequencies 6 and 9, respectively. Hence the combined frequency is the highest common factor between 6 and 9, i.e., 3. Hence period is 1/3.

Q.70 The autocorrelation of a rectangular pulse is

- (A) another rectangle pulse (B) Square pulse
- (C) Triangular pulse (D) Sinc pulse

Ans: (C)

Autocorrelation involves the integration of a constant which gives a ramp function. Hence the triangular pulse.

Q.71 If the Fourier series coefficients of a signal are periodic then the signal must be

- (A) continuous-time, periodic (B) discrete-time, periodic
- (C) continuous-time, non periodic (D) discrete-time, non periodic

Ans: (B)

It is the property of the discrete-time periodic signal.

Q.72 The area under the curve $\int_{-\infty}^{\infty} \delta(t) dt$ is

- (A) ∞ (B) unity
- (C) 0 (D) undefined

Ans: (B)

$$\int_{-\infty}^{\infty} \delta(t) dt = 1$$

By definition of delta function,

Q.73 A transmission is said to be _____ if the response of the system is exact replica of the input signal.

- (A) LTI (B) Distorted
- (C) Distortionless (D) Causal

Ans: (C)

Since $y(n) = x(n)$.

Q.74 Laplace Transform of t^n is always equal to

- (A) $\frac{n}{s^n}$ (B) $\frac{n!}{s^n}$
 (C) $\frac{n!}{s^{n+1}}$ (D) All

Ans: (C)

$$\mathcal{L}\{t^n\} = \int_0^{\infty} t^n e^{-st} dt = \frac{n!}{s^{n+1}}$$

Q.75 For a stable system

- (A) $|z| < 1$ (B) $|z| = 1$
 (C) $|z| > 1$ (D) $|z| \neq 1$

Ans: (A)

For the system to be stable, the ROC should include the unit circle.

Q.76 The region of convergence of a causal finite duration discrete time signal is

- (A) The entire 'z' plane except $z = 0$
 (B) The entire 'z' plane except $z = \infty$
 (C) The entire 'z' plane
 (D) A strip in z-plane

Ans: (A)

The ROC of the causal finite duration will have negative power of z. The ROC is the entire z-plane except $z = 0$.

Q.77 The CDF for a certain random variable is given as

$$F_x(x) = \begin{cases} 0, & -\infty < x \leq 0 \\ kx^2, & 0 < x \leq 10 \\ 100k, & 10 < x < \infty \end{cases}$$

The value of k is

- (A) 100 (B) 50
 (C) 1/50 (D) 1/100

Ans: (D)

From the given $F(x)$, we get

$$\frac{dF(x)}{dx} = 0 + 2kx + 0 = 2kx$$

$$\therefore \int_0^{10} 2kx dx = 1$$

$$\text{or } 100k = 1 \rightarrow k = 1/100$$

Q.78 The group delay function $\tau(\omega)$ is related to phase function $\phi(\omega)$ as

- (A) $\tau(\omega) = \frac{-d}{d\omega} \phi(\omega)$ (B) $\tau(\omega) = \frac{d}{d\omega^2} \phi(\omega)$

(C) $\tau(\omega) = \frac{d^2}{d\omega^2} \phi(\omega)$

(D) $\tau(\omega) = \frac{d^2}{d\omega} \phi(\omega)$

Ans: (A): By definition.

- Q.79** Two sequences $x_1(n)$ and $x_2(n)$ are related by $x_2(n) = x_1(-n)$. In the Z-domain, their ROCs are
 (A) same (B) reciprocal of each other
 (C) negative of each other (D) complement of each other

Ans: (B)
 ROC of $Z[x_2(n)]$ is outside the circle of radius r_2 while ROC of $Z[x_1(-n)]$ is inside the circle of radius r_1 such that $r_2 = 1/r_1$.

- Q.80** The autocorrelation of a sinusoid is
 (A) Sinc pulse (B) another sinusoid
 (C) Rectangular pulse (D) Triangular pulse

Ans: (B)

$$\begin{aligned} \phi_{xx}(t) &= \int_{-\infty}^{\infty} x(\tau)x(\tau-t)d\tau \\ &= \int_{-\infty}^{\infty} A \sin \omega\tau \times A \sin \omega(\tau-t)d\tau \\ &= \frac{A^2}{2} \int_{-\infty}^{\infty} [(\cos t - \cos 2\omega\tau.\cos t - \sin 2\omega\tau.\sin t)]d\tau \\ &= \frac{A^2}{2} K \left[\int_{-\pi}^{\pi} [(\cos t - \cos 2\omega\tau.\cos t - \sin 2\omega\tau.\sin t)]d\tau \right] \\ &= \frac{A^2}{2} K \left[\int_{-\pi}^{\pi} [\cos t]d\tau \right] = K' \cos t \end{aligned}$$

Thus the autocorrelation is a sinusoid.

- Q.81** Which of the following is true for the system represented by $y(n) = x(-n)$
 (A) Linear (B) Time invariant
 (C) Causal (D) Non Linear

Ans.: (A)

The given function is of the form $y = mx$. Hence linear.

- Q.82** The Fourier transform of impulse function is
 (A) $\delta(\omega)$ (B) $2\pi\omega$
 (C) 1 (D) $\text{sinc } f$

Ans: (C)

FT of $\delta(t) = \int_{-\infty}^{\infty} \delta(t)e^{-j\omega t} dt = 1$

- Q.83** Convolution is used to find
 (A) amount of similarity between the signals

- (B) response of the system
- (C) multiplication of the signals
- (D) Fourier transform

Ans: (B)

Convolution of the input signal $x(n)$ and the impulse response $h(n)$ is given by

$$y(n) = x(n) * h(n) = \sum_{k=-\infty}^{\infty} x(k)h(n-k)$$

, where $y(n)$ is the response of the system.

Q.84 The final value of $x(t) = [2 + e^{-3t}]u(t)$ is

- (A) 2
- (B) 3
- (C) e^{-3t}
- (D) 0

Ans: (A)

$$\text{Final value} = \lim_{t \rightarrow \infty} x(t) = \lim_{t \rightarrow \infty} [2 + e^{-3t}]u(t) = 2$$

Q.85 Discrete time system is stable if the poles are

- (A) within unit circle
- (B) outside unit circle
- (C) on the unit circle
- (D) None

Ans: (A)

The ROC should include the unit circle.

Q.86 The z transform of $-u(-n-1)$ is

- (A) $\frac{1}{1-z}$
- (B) $\frac{z}{1-z}$
- (C) $\frac{1}{1-z^{-1}}$
- (D) $\frac{z}{1-z^{-1}}$

Ans: (C)

$$z[-u(-n-1)] = -\sum_{n=-1}^{-\infty} [u(-n-1)]z^{-n} = -[z + z^2 + z^3 + \dots] = \frac{z}{z-1} = \frac{1}{1-z^{-1}}$$

Q.87 The area under Gaussian pulse $\int_{-\infty}^{\infty} e^{-\pi t^2} dt$ is

- (A) Unity
- (B) Infinity
- (C) Pulse
- (D) Zero

Ans: (A)

$$\int_{-\infty}^{\infty} e^{-\pi t^2} dt = \int_{-\infty}^{\infty} e^{-x} 2\pi \sqrt{\frac{x}{\pi}} dx = 2\sqrt{\pi} \int_{-\infty}^{\infty} \sqrt{x} e^{-x} dx = 1$$

Q.88 The spectral density of white noise is

- (A) Exponential
- (B) Uniform
- (C) Poisson
- (D) Gaussian

Ans: (B)

The distribution of White noise is homogeneous over all frequencies. Power spectrum is the Fourier transform of the autocorrelation function. Therefore, power spectral density of white noise is uniform.

PART – II

NUMERICALS & DERIVATIONS

Q.1. Determine whether the system having input $x(n)$ and output $y(n)$ and described by

relationship : $y(n) = \sum_{k=-\infty}^n x(k+2)$ is (i) memoryless, (ii) stable, (iii)causal (iv) linear and (v) time invariant. (5)

Ans:

$$y(n) = \sum_{k=-\infty}^n x(k+2)$$

- (i) Not memoryless - as $y(n)$ depends on past values of input from $x(-\infty)$ to $x(n-1)$ (assuming $n > 0$)
- (ii) Unstable- since if $|x(n)| \leq M$, then $|y(n)|$ goes to ∞ for any n .
- (iii) Non-causal - as $y(n)$ depends on $x(n+1)$ as well as $x(n+2)$.
- (iv) Linear - the principle of superposition applies (due to \sum operation)
- (v) Time – invariant - a time-shift in input results in corresponding time-shift in output.

Q.2. Determine whether the signal $x(t)$ described by

$x(t) = \exp[-at] u(t)$, $a > 0$ is a power signal or energy signal or neither. (5)

Ans:

$$x(t) = e^{-at} u(t), a > 0$$

$x(t)$ is a non-periodic signal.

$$\text{Energy } E = \int_{-\infty}^{+\infty} x^2(t) dt = \int_0^{\infty} e^{-2at} dt = \left. \frac{e^{-2at}}{-2a} \right|_0^{\infty} = \frac{1}{2a} \text{ (finite, positive)}$$

The energy is finite and deterministic.

$\therefore x(t)$ is an energy signal.

Q.3. Determine the even and odd parts of the signal $x(t)$ given by

$$x(t) = \begin{cases} A e^{-\alpha t} & t > 0 \\ 0 & t < 0 \end{cases}$$

$$x(t) = \begin{cases} A e^{-\alpha t} & t > 0 \\ 0 & t < 0 \end{cases} \quad (5)$$

Ans:

Assumption : $\alpha > 0, A > 0, -\infty < t < \infty$

$$\text{Even part } x_e(t) = \frac{x(t) + x(-t)}{2}$$

$$\text{Odd part } x_o(t) = \frac{x(t) - x(-t)}{2}$$

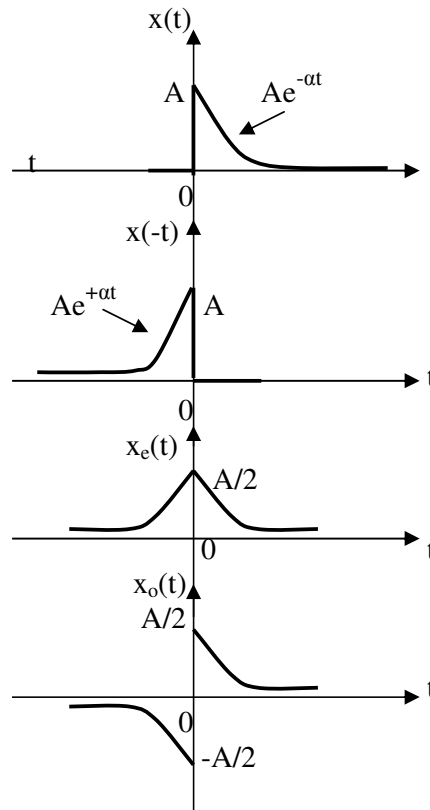

Q.4. Use one sided Laplace transform to determine the output $y(t)$ of a system described by

$$\frac{d^2y}{dt^2} + 3\frac{dy}{dt} + 2y(t) = 0 \text{ where } y(0^-) = 3 \text{ and } \left. \frac{dy}{dt} \right|_{t=0^-} = 1 \tag{7}$$

Ans:

$$\frac{d^2y}{dt^2} + 3\frac{dy}{dt} + 2y(t) = 0, \quad y(0^-) = 3, \quad \left. \frac{dy}{dt} \right|_{t=0^-} = 1$$

$$\left[s^2 Y(s) - s y(0) - \left. \frac{dy}{dt} \right|_{t=0} \right] + 3 [s Y(s) - y(0)] + 2 Y(s) = 0$$

$$(s^2 + 3s + 2) Y(s) = s y(0) + \left. \frac{dy}{dt} \right|_{t=0} + 3 y(0)$$

$$(s^2 + 3s + 2) Y(s) = 3s + 1 + 9 = 3s + 10$$

$$Y(s) = \frac{3s + 10}{s^2 + 3s + 2} = \frac{3s + 10}{(s + 1)(s + 2)}$$

$$= \frac{A}{s + 1} + \frac{B}{s + 2}$$

$$A = \left. \frac{3s + 10}{s + 2} \right|_{s = -1} = 7; \quad B = \left. \frac{3s + 10}{s + 1} \right|_{s = -2} = -4$$

$$\therefore Y(s) = \frac{7}{s + 1} - \frac{4}{s + 2}$$

$$\therefore y(t) = L^{-1} [Y(s)] = 7e^{-t} - 4e^{-2t} = e^{-t}(7 - 4e^{-t})$$

\therefore The output of the system is $y(t) = e^{-t}(7 - 4e^{-t}) u(t)$

Q. 5. Obtain two different realizations of the system given by $y(n] - (a+b) y(n - 1) + aby(n - 2) = x(n)$. Also obtain its transfer function. (7)

Ans:

$$y(n] - (a + b) y(n-1) + ab y(n-2) = x(n)$$

$$\therefore Y(z) - (a+b) z^{-1} Y(z) + ab z^{-2} Y(z) = X(z)$$

$$\text{Transfer function } H(z) = \frac{Y(z)}{X(z)} = \frac{1}{1 - (a+b) z^{-1} + ab z^{-2}}$$

$$y(n] = x(n) + (a + b) y(n-1) - ab y(n-2)$$

Direct Form I/II realization

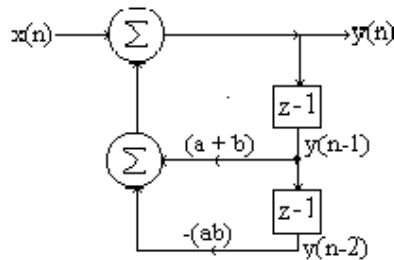

Alternative Realisation

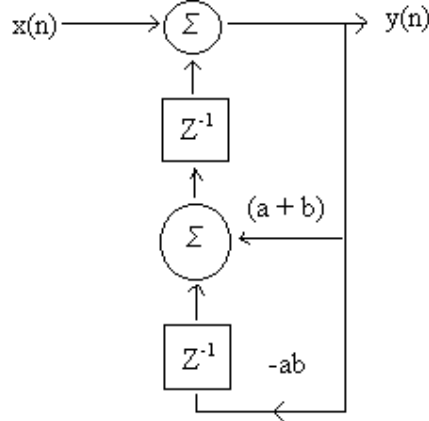

Q. 6. An LTI system has an impulse response $h(t) = \exp[-at] u(t)$; when it is excited by an input signal $x(t)$, its output is $y(t) = [\exp(-bt) - \exp(-ct)] u(t)$. Determine its input $x(t)$. (7)

Ans:

$$h(t) = e^{-at} u(t) \text{ for input } x(t)$$

$$\text{Output } y(t) = (e^{-bt} - e^{-ct}) u(t)$$

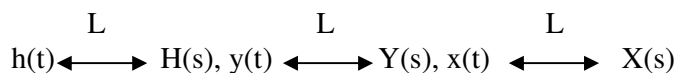

$$H(s) = \frac{1}{s+a} ; Y(s) = \frac{1}{s+b} - \frac{1}{s+c} = \frac{s+c-s-b}{(s+b)(s+c)} = \frac{c-b}{(s+b)(s+c)}$$

$$\text{As } H(s) = \frac{Y(s)}{X(s)} , X(s) = \frac{Y(s)}{H(s)}$$

$$\therefore X(s) = \frac{(c-b)(s+a)}{(s+b)(s+c)} = \frac{A}{s+b} + \frac{B}{s+c}$$

$$A = \left. \frac{(c-b)(s+a)}{(s+c)} \right|_{s=-b} = \frac{(c-b)(-b+a)}{(-b+c)} = a-b$$

$$B = \left. \frac{(c-b)(s+a)}{(s+b)} \right|_{s=-c} = \frac{(c-b)(-c+a)}{(-c+b)} = c-a$$

$$\therefore X(s) = \frac{a-b}{s+b} + \frac{c-a}{s+c}$$

$$x(t) = (a-b) e^{-bt} + (c-a) e^{-ct}$$

$$\therefore \text{The input } x(t) = [(a-b) e^{-bt} + (c-a) e^{-ct}] u(t)$$

Q.7. Write an expression for the waveform $f(t)$ shown in Fig. using only unit step function and powers of t . (3)

Ans:

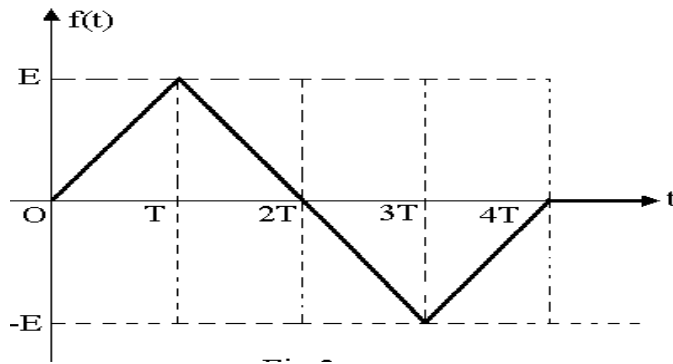

$$\therefore f(t) = \frac{E}{T} [t u(t) - 2(t-T) u(t-T) + 2(t-3T) u(t-3T) - (t-4T) u(t-4T)]$$

Q.8. For $f(t)$ of Q7, find and sketch $f'(t)$ (prime denotes differentiation with respect to t). (3)

Ans:

$$f(t) = \frac{E}{T} [t u(t) - 2(t-T) u(t-T) + 2(t-3T) u(t-3T) - (t-4T) u(t-4T)]$$

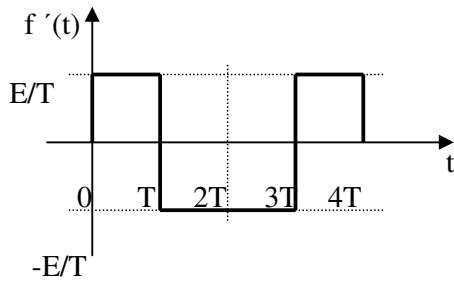

$$\therefore f'(t) = \frac{E}{T} [u(t) - 2u(t - T) + 2u(t - 2T) - u(t - 3T)]$$

Q.9. Define a unit impulse function $\delta(t)$. (2)

Ans:

Unit impulse function $\delta(t)$ is defined as:

$$\begin{cases} \delta(t) = 0, t \neq 0 \\ \int_{-\infty}^{+\infty} \delta(t) dt = 1 \end{cases}$$

It can be viewed as the limit of a rectangular pulse of duration a and height $1/a$ when $a \rightarrow 0$, as shown below.

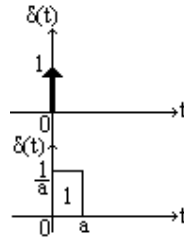

Q.10. Sketch the function $g(t) = \frac{3}{\epsilon^3} (t - \epsilon)^2 [u(t) - u(t - \epsilon)]$ and show that $g(t) \rightarrow \delta(t)$ as $\epsilon \rightarrow 0$. (6)

Ans:

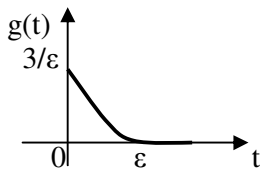

As $\epsilon \rightarrow 0$, duration $\rightarrow 0$, amplitude $\rightarrow \infty$
 $\int_0^\epsilon g(t) dt = 1$

Q.11. Show that if the FT of $x(t)$ is $X(j\omega)$, then the FT of $x\left(\frac{t}{a}\right)$ is $|a|X(ja\omega)$. (6)

Ans:

$$x(t) \xleftrightarrow{\text{FT}} X(j\omega)$$

Let $x \left[\begin{matrix} t \\ a \end{matrix} \right] \xleftrightarrow{\text{FT}} X_1(j\omega)$, then

$$X_1(j\omega) = \int_{-\infty}^{+\infty} x \left[\begin{matrix} t \\ a \end{matrix} \right] e^{-j\omega t} dt \quad \text{Let } t = a\alpha \quad \therefore dt = a d\alpha$$

$$= \int_{-\infty}^{+\infty} x(\alpha) e^{-j\omega a\alpha} a d\alpha \text{ if } a > 0$$

$$- \int_{-\infty}^{+\infty} x(\alpha) e^{-j\omega a\alpha} a d\alpha \text{ if } a < 0$$

Hence $X_1(j\omega) = |a| \int_{-\infty}^{+\infty} x(\alpha) e^{-j\omega a\alpha} d\alpha = |a| x(j\omega a)$

Q.12. Solve, by using Laplace transforms, the following set of simultaneous differential equations for $x(t)$. (14)

Ans:

$$2x'(t) + 4x(t) + y'(t) + 7y(t) = 5u(t)$$

$$x'(t) + x(t) + y'(t) + 3y(t) = 5\delta(t)$$

The initial conditions are : $x(0^-) = y(0^-) = 0$.

$$2x'(t) + 4x(t) + y'(t) + 7y(t) = 5u(t)$$

$$x'(t) + x(t) + y'(t) + 3y(t) = 5\delta(t)$$

$$\begin{matrix} \text{L} & & \text{L} & & \text{L} & & \text{L} \\ x(t) & \longleftrightarrow & X(s), & x'(t) & \longleftrightarrow & sX(s), & \delta(t) & \longleftrightarrow & 1, & u(t) & \longleftrightarrow & \frac{1}{s} \end{matrix}$$

(Given zero initial conditions)

$$\therefore 2sX(s) + 4X(s) + sY(s) + 7Y(s) = \frac{5}{s}$$

$$sX(s) + X(s) + sY(s) + 3Y(s) = 5$$

$$(2s + 4)X(s) + (s+7)Y(s) = \frac{5}{s}$$

$$(s + 1)X(s) + (s+3)Y(s) = 5$$

$$X(s) = \frac{\begin{vmatrix} \frac{5}{s} & s+7 \\ 5 & s+3 \end{vmatrix}}{\begin{vmatrix} 2s+4 & s+7 \\ s+1 & s+3 \end{vmatrix}}$$

Or, $X(s) = - \frac{5s + 35 - 5 - 15/s}{2s^2 + 6s + 4s + 12 - s^2 - 8s - 7}$

$$= - \frac{5s^2 + 30s - 15}{s(s^2 + 2s + 5)} = - \frac{5}{s} \left(\frac{s^2 + 6s - 3}{s^2 + 2s + 5} \right) = \frac{A}{s} + \frac{Bs + C}{s^2 + 2s + 5}$$

Then $A(s^2 + 2s + 5) + Bs^2 + Cs = -5(s^2 + 6s - 3)$

$$\therefore A + B = -5$$

$$2A + C = -30$$

5A = 15

Thus A = 3, B = -8, C = -36 and we can write

$$X(s) = \frac{3}{s} - \frac{8}{(s+1)^2 + 2^2} - 14 \frac{2}{(s+1)^2 + 2^2}$$

$$\therefore x(t) = (3 - 8 e^{-t} \cos 2t - 14 e^{-t} \sin 2t) u(t)$$

Q.13. Find the Laplace transform of $t \sin \omega_0 t u(t)$. (6)

Ans:

$$\sin(\omega_0 t) \xleftrightarrow{L} \frac{\omega_0}{s^2 + \omega_0^2}$$

$$\text{Using } t f(t) \xleftrightarrow{L} -\frac{d}{ds} [F(s)],$$

$$L [t \sin(\omega_0 t) u(t)] = -\frac{d}{ds} \left[\frac{\omega_0}{s^2 + \omega_0^2} \right]$$

$$= \left[\frac{0 - \omega_0(2s)}{(s^2 + \omega_0^2)^2} \right] = \frac{2\omega_0 s}{(s^2 + \omega_0^2)^2}$$

Q.14. Find the inverse Laplace transform of $\frac{s-2}{s(s+1)^3}$. (8)

Ans:

$$F(s) = \frac{s-2}{s(s+1)^3} = \frac{A}{s} + \frac{B}{s+1} + \frac{C}{(s+1)^2} + \frac{D}{(s+1)^3}$$

$$A = \frac{s-2}{(s+1)^3} \Big|_{s=0} = -2 \qquad A(s+1)^3 + Bs(s+1)^2 + Cs(s+1) + Ds = s-2$$

$$s^3 : A+B = 0 \qquad \text{B} = 2$$

$$D = \frac{s-2}{s} \Big|_{s=-1} = 3$$

$$s^2 : 3A + 2B + C = 0 \qquad \text{C} = 2$$

$$\text{A} = -2 \qquad \text{D} = 3$$

$$F(s) = \frac{-2}{s} + \frac{2}{s+1} + \frac{2}{(s+1)^2} + \frac{3}{(s+1)^3}$$

$$\therefore f(t) = -2 + 2 e^{-t} + 2 t e^{-t} + \frac{3}{2} t^2 e^{-t}$$

$$\therefore f(t) = [-2 + e^{-t} (\frac{3}{2} t^2 + 2t + 2)] u(t)$$

Q.15. Show that the difference equation $y(n) - \alpha y(n-1) = -\alpha x(n) + x(n-1)$ represents an all-pass transfer function. What is (are) the condition(s) on α for the system to be stable? (8)

Ans:

$$y(n) - \alpha y(n-1) = -\alpha x(n) + x(n-1)$$

$$Y(z) - \alpha z^{-1} Y(z) = -\alpha X(z) + z^{-1} X(z)$$

$$(1 - \alpha z^{-1}) Y(z) = (-\alpha + z^{-1}) X(z)$$

$$H(z) = \frac{Y(z)}{X(z)} = \frac{-\alpha + z^{-1}}{1 - \alpha z^{-1}} = \frac{1 - \alpha z}{z - \alpha}$$

Zero : $z = \frac{1}{\alpha}$	As poles and zeros have reciprocal values, the transfer function represents an all pass filter system.
-------------------------------	--

Pole : $z = \alpha$

Condition for stability of the system :

For stability, the pole at $z = \alpha$ must be inside the unit circle, i.e. $|\alpha| < 1$.

Q.16. Give a recursive realization of the transfer function $H(z) = 1 + z^{-1} + z^{-2} + z^{-3}$ (6)

Ans:

$$H(z) = 1 + z^{-1} + z^{-2} + z^{-3} = \frac{1 - z^{-4}}{1 - z^{-1}} \left[\begin{array}{l} \text{Geometric series of 4 terms} \\ \text{First term} = 1, \text{ Common ratio} = z^{-1} \end{array} \right]$$

As $H(z) = \frac{Y(z)}{X(z)}$, we can write

$$\therefore (1 - z^{-1}) Y(z) = (1 - z^{-4}) X(z) \text{ or } Y(z) = \frac{X(z)}{(1 - z^{-1})} (1 - z^{-4}) = W(z)(1 - z^{-4})$$

The realization of the system is shown below.

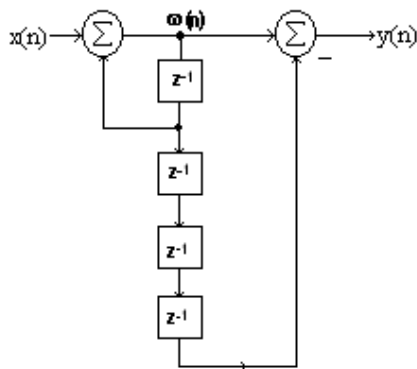

Q.17 Determine the z-transform of $x_1(n) = \alpha^n u(n)$ and $x_2(n) = -\alpha^n u(-n-1)$ and indicate their regions of convergence. (6)

Ans:

$$x_1(n) = \alpha^n u(n) \quad \text{and} \quad x_2(n) = -\alpha^n u(-n-1)$$

$$X_1(z) = \frac{1}{1-\alpha z^{-1}} \quad \text{RoC } |\alpha z^{-1}| < 1 \text{ i.e., } |z| > \alpha$$

$$\begin{aligned} X_2(z) &= \sum_{n=-\infty}^{-1} -\alpha^n z^{-n} \\ &= -\sum_{n=1}^{\infty} \alpha^{-n} z^n = -(\alpha^{-1}z + \alpha^{-2}z^2 + \alpha^{-3}z^3 + \dots) \\ &= -\alpha^{-1}z (1 + \alpha^{-1}z + \alpha^{-2}z^2 + \dots) \\ &= \frac{-\alpha^{-1}z}{1-\alpha^{-1}z} = \frac{z}{z-\alpha} = \frac{1}{1-\alpha z^{-1}}; \quad \text{RoC } |\alpha^{-1}z| < 1 \text{ i.e., } |z| < |\alpha| \end{aligned}$$

Q.18. Determine the sequence $h(n)$ whose z-transform is

$$H(z) = \frac{1}{1-2r \cos \theta z^{-1} + r^2 z^{-2}}, \quad |r| < 1. \quad (6)$$

Ans:

$$\begin{aligned} H(z) &= \frac{1}{1-2r \cos \theta z^{-1} + r^2 z^{-2}}, \quad |r| < 1 \\ &= \frac{1}{(1-r e^{j\theta} z^{-1})(1-r e^{-j\theta} z^{-1})}, \quad |r| < 1 \\ &= \frac{A}{(1-r e^{j\theta} z^{-1})} + \frac{B}{(1-r e^{-j\theta} z^{-1})} = |r| < 1 \end{aligned}$$

$$\text{where } A = \left. \frac{1}{(1-r e^{j\theta} z^{-1})} \right|_{r e^{j\theta} z^{-1}=1} = \frac{1}{1-e^{-j2\theta}}$$

$$B = \left. \frac{1}{(1-r e^{-j\theta} z^{-1})} \right|_{r e^{-j\theta} z^{-1}=1} = \frac{1}{1-e^{j2\theta}}$$

$$\therefore h(n) = \frac{1}{1-e^{-j2\theta}} (r e^{j\theta})^n + \frac{1}{1-e^{j2\theta}} (r e^{-j\theta})^n$$

$$\therefore h(n) = r^n \left[\frac{e^{jn\theta}}{1-e^{-j2\theta}} + \frac{e^{-jn\theta}}{1-e^{j2\theta}} \right] u(n)$$

$$= r^n \frac{e^{j(n+1)\theta} - e^{-j(n+1)\theta}}{e^{j\theta} - e^{-j\theta}} u(n)$$

$$= \frac{r^n \sin(n+1)\theta}{\sin\theta} u(n)$$

Q.19. Let the Z-transform of $x(n]$ be $X(z)$. Show that the z-transform of $x(-n]$ is $X\left(\frac{1}{z}\right)$. (2)

Ans:

$$x(n) \xleftrightarrow{z} X(z) \quad \text{Let } y(n) = x(-n)$$

$$\text{Then } Y(z) = \sum_{n=-\infty}^{\infty} x(-n)z^{-n} = \sum_{r=-\infty}^{\infty} x(r)z^{+r} = \sum_{r=-\infty}^{\infty} x(r)(z^{-1})^{-1} = X(z^{-1})$$

Q.20. Find the energy content in the signal $x(n) = e^{-n/10} \sin\left(\frac{2\pi n}{4}\right)$. (7)

Ans:

$$x(n) = e^{-0.1n} \sin\left(\frac{2\pi n}{4}\right)$$

$$\text{Energy content } E = \sum_{n=-\infty}^{+\infty} |x^2(n)| = \sum_{n=-\infty}^{+\infty} e^{-0.2n} \left[\sin\left(\frac{2\pi n}{4}\right) \right]^2$$

$$E = \sum_{n=-\infty}^{+\infty} e^{-2n} \frac{\sin^2 n\pi}{2}$$

$$E = \sum_{n=-\infty}^{+\infty} e^{-2n} \frac{1 - \cos n\pi}{2}$$

$$= \frac{1}{2} \sum_{n=-\infty}^{+\infty} e^{-2n} [1 - (-1)^n]$$

Now $1 - (-1)^n = \begin{cases} 2 & \text{for } n \text{ odd} \\ 0 & \text{for } n \text{ even} \end{cases}$

$$\text{Also Let } n = 2r + 1; \text{ then } E = \sum_{r=-\infty}^{\infty} e^{-2(2r+1)} = \sum_{r=-\infty}^{\infty} e^{-4r} e^{-2}$$

$$= e^{-2} \left[\sum_{r=0}^{\infty} e^{-4r} + \sum_{r=1}^{\infty} e^{4r} \right] \quad \text{The second term in brackets goes to infinity. Hence } E \text{ is infinite.}$$

Q.21. Sketch the odd part of the signal shown in Fig. (3)

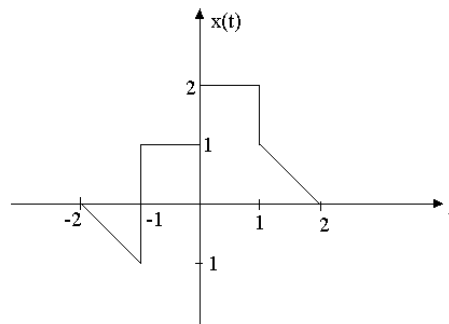

Ans:

Odd part $x_o(t) = \frac{x(t) - x(-t)}{2}$

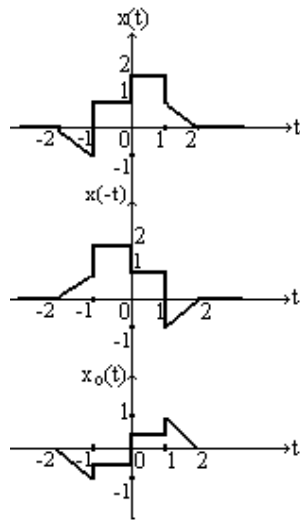

Q.22. A linear system H has an input-output pair as shown in Fig. Determine whether the system is causal and time-invariant. (4)

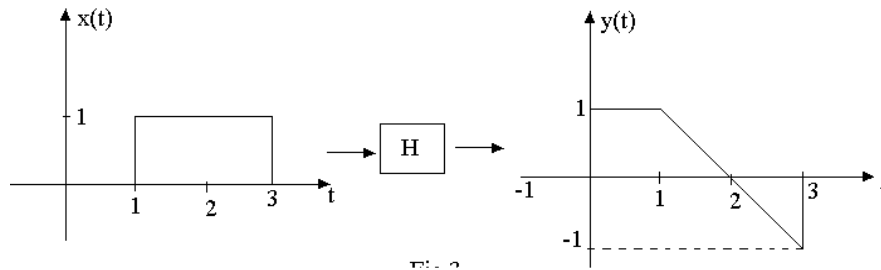

Ans:

System is non-causal ∵ the output y(t) exists at t = 0 when input x(t) starts only at t = +1.

System is time-varying ∵ the expression for y(t) = [u (t) - u (t-1)(t-1) + u (t-3)

(t-3) - u (t-3)] shows that the system H has time varying parameters.

Q.23. Determine whether the system characterized by the differential equation $\frac{d^2y(t)}{dt^2} - \frac{dy(t)}{dt} + 2y(t) = x(t)$ is stable or not. (4)

Ans:

$$\frac{d^2y(t)}{dt^2} - \frac{dy(t)}{dt} + 2y(t) = x(t)$$

$$y(t) \xleftrightarrow{L} Y(s); \quad x(t) \xleftrightarrow{L} X(s); \text{ Zero initial conditions}$$

$$s^2 Y(s) - sY(s) + 2Y(s) = X(s)$$

System transfer function $\frac{Y(s)}{X(s)} = \frac{1}{s^2 - s + 2}$ whose poles are in the right half plane.

Hence the system is not stable.

Q.24 Determine whether the system $y(t) = \int_{-\infty}^t x(\tau) d\tau$ is invertible. (5)

Ans:

$$y(t) = \int_{-\infty}^t x(\tau) d\tau$$

Condition for invertibility: $H^{-1}H = I$ (Identity operator)

$$\begin{cases} H \rightarrow \text{Integration} \\ H^{-1} \rightarrow \text{Differentiation} \end{cases}$$

$$x(t) \rightarrow y(t) = H\{x(t)\}$$

$$H^{-1}\{y(t)\} = H^{-1}H\{x(t)\} = x(t)$$

∴ The system is invertible.

Q.25 Find the impulse response of a system characterized by the differential equation $y'(t) + a y(t) = x(t)$. (5)

Ans:

$$y'(t) + a y(t) = x(t)$$

$$x(t) \xleftrightarrow{L} X(s), y(t) \xleftrightarrow{L} Y(s), h(t) \xleftrightarrow{L} H(s)$$

$sY(s) + aY(s) = X(s)$, assuming zero initial conditions

$$H(s) = \frac{Y(s)}{X(s)} = \frac{1}{s + a}$$

∴ The impulse response of the system is $h(t) = e^{-at} u(t)$

Q.26. Compute the Laplace transform of the signal $y(t) = (1 + 0.5 \sin t) \sin 1000t$. (4)

Ans:

$$y(t) = (1 + 0.5 \sin t) \sin 1000t$$

$$= \sin 1000t + 0.5 \sin t \sin 1000t$$

$$= \sin 1000t + 0.5 \left[\frac{\cos 999t - \cos 1001t}{2} \right]$$

$$= \sin 1000t + 0.25 \cos 999t - 0.25 \cos 1001t$$

$$\therefore Y(s) = \frac{1000}{s^2 + 1000^2} + 0.25 \frac{s}{s^2 + 999^2} - 0.25 \frac{s}{s^2 + 1001^2}$$

- Q.27.** Determine Fourier Transform $F(\omega)$ of the signal $f(t) = e^{-\alpha t} \cos(\omega t + \theta)$ and determine the value of $|F(\omega)|$. (7)

Ans:

We assume $f(t) = e^{-\alpha t} \cos(\omega t + \theta) u(t)$ because otherwise FT does not exist

$$f(t) \xrightarrow{\text{FT}} F(\omega) = \int_0^{+\infty} e^{-\alpha t} \frac{e^{j(\omega t + \theta)} + e^{-j(\omega t + \theta)}}{2} e^{-j\omega t} dt$$

$$\begin{aligned} \therefore F(\omega) &= \frac{1}{2} \int_0^{+\infty} [e^{-\alpha t} e^{-j\omega t} e^{j\omega t + j\theta} + e^{-\alpha t} e^{-j\omega t} e^{-j\omega t - j\theta}] dt \\ &= \frac{1}{2} \int_0^{+\infty} [e^{-\alpha t + j\theta} + e^{-j\theta} e^{-(\alpha + 2j\omega)t}] dt \end{aligned}$$

$$\begin{aligned} |F(\omega)| &= \frac{1}{2} \left| e^{j\theta} \frac{e^{-\alpha}}{-\alpha} \Big|_0^{+\infty} + e^{-j\theta} \frac{e^{-(\alpha + 2j\omega)t}}{-(\alpha + 2j\omega)} \Big|_0^{+\infty} \right| \\ &= \frac{1}{2} \left| \frac{1}{\alpha} e^{j\theta} + \frac{1}{\alpha + 2j\omega} e^{-j\theta} \right| \end{aligned}$$

$$\begin{aligned} \therefore |F(\omega)| &= \frac{1}{2} \left| \frac{(\alpha + 2j\omega) e^{j\theta} + \alpha e^{-j\theta}}{\alpha(\alpha + 2j\omega)} \right| \\ &= \frac{1}{2} \left| \frac{2\alpha \cos \theta + 2j\omega e^{j\theta}}{\alpha(\alpha + 2j\omega)} \right| \\ &= \left| \frac{\alpha \cos \theta + j\omega \cos \theta - j\omega \sin \theta}{\alpha(\alpha + 2j\omega)} \right| \\ |F(\omega)|^2 &= \frac{\alpha^2 \cos^2 \theta + \omega^2 - 2\alpha\omega \sin \theta + \cos \theta}{\alpha^2 (\alpha^2 + 4\omega^2)} \\ &= \frac{\omega^2 + \alpha^2 \cos^2 \theta - \alpha\omega \sin 2\theta}{\alpha^2 (\alpha^2 + 4\omega^2)} \end{aligned}$$

- Q.28.** Determine the impulse response $h(t)$ and sketch the magnitude and phase response of the system described by the transfer function (14)

$$H(s) = \frac{s^2 + \omega_0^2}{s^2 + \frac{\omega_0}{Q}s + \omega_0^2}$$

Ans:

$$H(s) = \frac{s^2 + \omega_0^2}{s^2 + \frac{\omega_0}{Q}s + \omega_0^2}$$

$$H(j\omega) = \frac{(j\omega)^2 + \omega_0^2}{(j\omega)^2 + \frac{\omega_0}{Q}(j\omega) + \omega_0^2} = \frac{\omega_0^2 - \omega^2}{\omega_0^2 - \omega^2 + j\omega \frac{\omega_0}{Q}}$$

$$\therefore |H(j\omega)| = \left| \frac{\omega_0^2 - \omega^2}{(\omega_0^2 - \omega^2)^2 + \omega^2 \left(\frac{\omega_0}{Q}\right)^2} \right|^{1/2}$$

$$\text{Arg } H(j\omega) = -\tan^{-1} \left(\frac{\omega \left(\frac{\omega_0}{Q}\right)}{\omega_0^2 - \omega^2} \right)$$

ω	$ H(j\omega) $	$\text{Arg } H(j\omega)$
0	1	0
∞	1	0
ω_{0-}	0	$-\pi/2$
ω_{0+}	0	$+\pi/2$

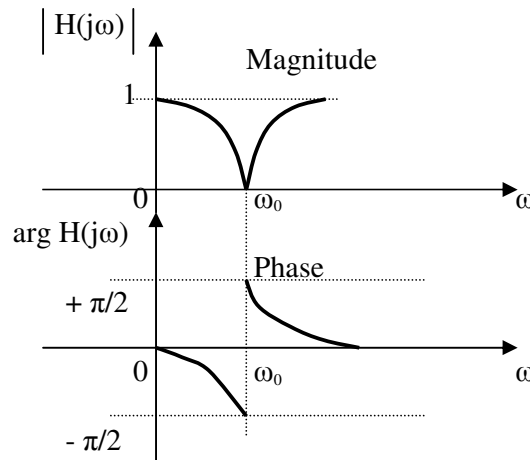

Q.29. Using the convolution sum, determine the output of the digital system shown in Fig. below.

Assume that the input sequence is $\{x(n)\} = \{3, -1, 3\}$ and that the system is initially at rest.

(5)

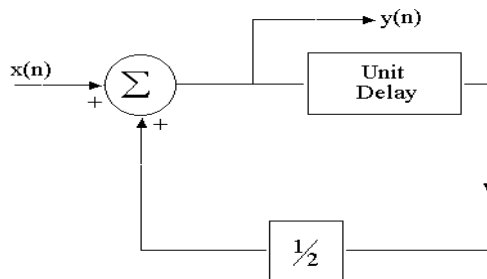

Ans:

$x(n) = \{3, -1, 3\}$, system at rest initially (zero initial conditions)

\uparrow
n = 0

$$x(n) = 3\delta(n) - \delta(n-1) + 3\delta(n-2)$$

$$X(z) = 3 - z^{-1} + 3z^{-2}$$

Digital system: $y(n] = x(n) + \frac{1}{2} y(n-1)$

$$\therefore Y(z) = \frac{X(z)}{1 - \frac{1}{2} z^{-1}} = \frac{3 - z^{-1} + 3z^{-2}}{1 - \frac{1}{2} z^{-1}} = -10 - 6 z^{-1} + \frac{13}{1 - \frac{1}{2} z^{-1}}$$

by partial fraction expansion.

$$\text{Hence } y(n) = -10 \delta(n) - 6 \delta(n-1) + 13 \left(\frac{1}{2}\right)^n u(n)$$

Q.30. Find the z-transform of the digital signal obtained by sampling the analog signal $e^{-4t} \sin 4t u(t)$ at intervals of 0.1 sec. (6)

Ans:

$$x(t) = e^{-4t} \sin 4t u(t), \quad T = 0.1 \text{ s}$$

$$x(n) = x(t \rightarrow nT) = x(0.1n) = (e^{-0.4})^n \sin(0.4n)$$

$$x(n) \xleftrightarrow{z} X(z)$$

$$x(n) = \sin \Omega n u(n) \xleftrightarrow{z} \frac{z \sin \Omega}{z^2 - 2z \cos \Omega + 1}$$

$$\alpha = e^{-0.4} = 0.6703, \quad \frac{1}{\alpha} = 1.4918$$

$$\Omega = 0.4 \text{ rad} = 22.92^\circ$$

$$\sin \Omega = 0.3894; \quad \cos \Omega = 0.9211$$

$$\alpha^n x(n) \xleftrightarrow{z} X(z/\alpha)$$

$$\therefore X(z) = \frac{1.4918z (0.3894)}{(1.4918)^2 z^2 - 2(1.4918)z(0.9211) + 1}$$

$$X(z) = \frac{0.5809z}{2.2255 z^2 - 2.7482z + 1}$$

Q.31. An LTI system is given by the difference equation $y(n] + 2y(n-1) + y(n-2) = x(n]$.

- i. Determine the unit impulse response.
- ii. Determine the response of the system to the input (3, -1, 3).

$$\begin{matrix} \uparrow \\ n = 0 \end{matrix}$$

(4)

Ans:

$$y(n] + 2y(n-1) + y(n-2) = x(n]$$

$$Y(z) + 2z^{-1} Y(z) + z^{-2} Y(z) = X(z)$$

$$(1 + 2z^{-1} + z^{-2})Y(z) = X(z)$$

$$(i). H(z) = \frac{Y(z)}{X(z)} = \frac{1}{1 + 2z^{-1} + z^{-2}} = \frac{1}{(1 + z^{-1})^2} \quad (\text{Binomial expansion})$$

$$= 1 - 2z^{-1} + 3z^{-2} - 4z^{-3} + 5z^{-4} - 6z^{-5} + 7z^{-6} - \dots (\text{Binomial expansion})$$

$$\therefore h(n) = \delta(n) - 2\delta(n-1) + 3\delta(n-2) - \dots$$

$= \{1, -2, 3, -4, 5, -6, 7, \dots\}$ is the impulse response.

$$(ii). x(n) = \{3, -1, 3\}$$

\uparrow
 $n=0$

$$= 3\delta(n) - \delta(n-1) + 3\delta(n-2)$$

$$X(z) = 3 - z^{-1} + 3z^{-2}$$

$$\therefore Y(z) = X(z).H(z) = \frac{3 - z^{-1} + 3z^{-2}}{1 + 2z^{-1} + z^{-2}} = \frac{3(1 + 2z^{-1} + z^{-2}) - 7z^{-1}}{1 + 2z^{-1} + z^{-2}}$$

$$= 3 - 7 \frac{z^{-1}}{(1 + z^{-1})^2}$$

$\therefore y(n) = 3\delta(n) + 7nu(n)$ is the required response of the system.

Q.32. The signal $x(t)$ shown below in Fig. is applied to the input of an

(i) ideal differentiator.

(ii) ideal integrator.

Sketch the responses.

$$x(t) = t u(t) - 3t u(t-1) + 2t u(t-1.5)$$

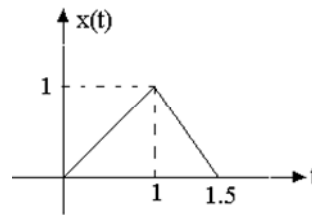

(1+4=5)

Ans:

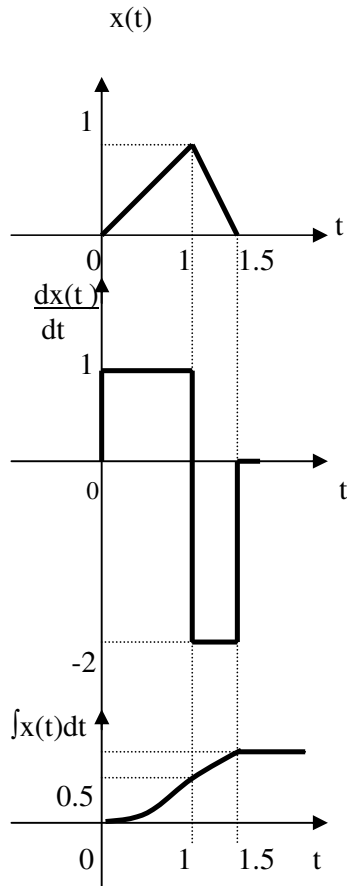

(i) $0 < t < 1$

$$y(t) = \int_0^t t \, dt = \left. \frac{t^2}{2} \right|_0^1 = 0.5 \text{ (Nonlinear)}$$

(ii) $1 < t < 1.5$

$$y(t) = y(1) + \int_1^t (3-2t) \, dt$$

$$= 0.5 + (3t - t^2) \Big|_1^t = 0.5 + 3t - t^2 - 3 + 1$$

$$= 3t - t^2 - 1.5 \text{ (Nonlinear)}$$

For $t=1$: $y(1) = 3 - 1 - 1.5 = 0.5$

(iii) $t \geq 1.5$: $y(1.5) = 4.5 - 2.25 - 1.5 = 0.75$

Q.33. Sketch the even and odd parts of

(1+2+3=6)

- (i) a unit impulse function
- (iii) a unit ramp function.

- (ii) a unit step function

Ans:

Even part $x_e(t) = \frac{x(t) + x(-t)}{2}$

Odd part $x_o(t) = \frac{x(t) - x(-t)}{2}$

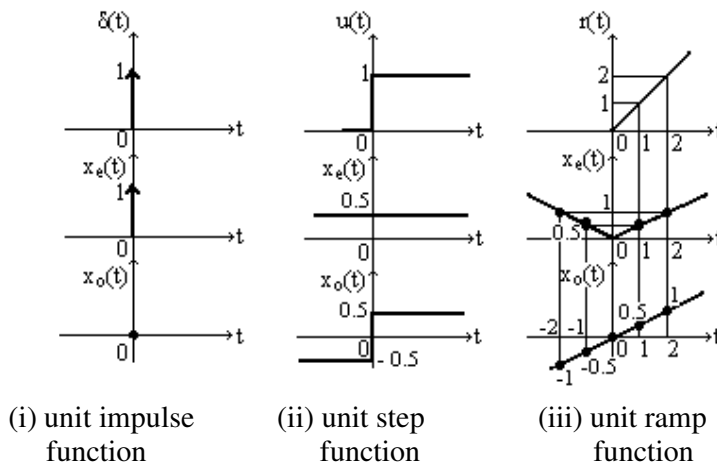

(i) unit impulse function

(ii) unit step function

(iii) unit ramp function

Q.34. Sketch the function $f(t) = u\left(\sin \frac{\pi t}{T}\right) - u\left(-\sin \frac{\pi t}{T}\right)$. (3)

Ans:

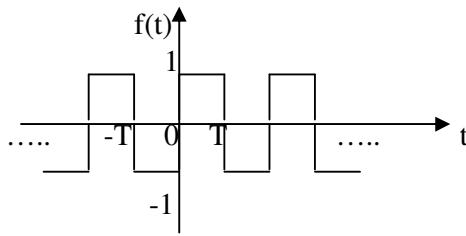

$$f(t) = \begin{cases} 1 & 0 < t < T, 2T < t < 3T \\ -1 & T < t < 2T, \dots \\ 3 & T < t < 4T, \dots \end{cases}$$

Q.35. Under what conditions, will the system characterized by $y(n) = \sum_{k=n_0}^{\infty} e^{-ak} x(n-k)$ be linear, time-invariant, causal, stable and memoryless? (5)

Ans:

$y(n)$ is : linear and time invariant for all k
 causal if n_0 not less than 0.
 stable if $a > 0$
 memoryless if $k = 0$ only

Q.36. Let E denote the energy of the signal $x(t)$. What is the energy of the signal $x(2t)$? (2)

Ans:

Given that

$$E = \int_{-\infty}^{\infty} |x(t)|^2 dt$$

To find $E^1 = \int_{-\infty}^{\infty} |x(2t)|^2 dt$

Let $2t = r$ then $E^1 = \int_{-\infty}^{\infty} |x(r)|^2 \frac{dr}{2} = \frac{1}{2} \int_{-\infty}^{\infty} |x(r)|^2 dr = \frac{E}{2}$

Q.37. $x(n)$, $h(n)$ and $y(n)$ are, respectively, the input signal, unit impulse response and output signal of a linear, time-invariant, causal system and it is given that $y(n-2) = x(n-n_1) * h(n-n_2)$, where $*$ denotes convolution. Find the possible sets of values of n_1 and n_2 . (3)

Ans:

$$\begin{aligned} y(n-2) &= x(n-n_1) * h(n-n_2) \\ \therefore z^{-2} Y(z) &= z^{-n_1} X(z) \cdot z^{-n_2} H(z) \\ z^{-2} H(z) X(z) &= z^{-(n_1+n_2)} X(z) H(z) \\ \therefore n_1+n_2 &= 2 \end{aligned}$$

Also, $n_1, n_2 \geq 0$, as the system is causal. So, the possible sets of values for n_1 and n_2 are:
 $\{n_1, n_2\} = \{(0,2), (1,1), (2,0)\}$

Q.38. Let $h(n)$ be the impulse response of the LTI causal system described by the difference equation $y(n) = a y(n-1) + x(n)$ and let $h(n) * h_1(n) = \delta(n)$. Find $h_1(n)$. (4)

Ans:

$$y(n) = a y(n-1) + x(n) \quad \text{and} \quad h(n) * h_1(n) = \delta(n)$$

$$Y(z) = az^{-1} Y(z) + X(z) \quad \text{and} \quad H(z) H_1(z) = 1$$

$$H(z) = \frac{Y(z)}{X(z)} = \frac{1}{1-az^{-1}} \quad \text{and} \quad H_1(z) = \frac{1}{H(z)}$$

$$\therefore H_1(z) = 1-az^{-1} \quad \text{or} \quad h_1(n) = \delta(n) - a \delta(n-1)$$

Q.39. Determine the Fourier series expansion of the waveform $f(t)$ shown below in terms of sines and cosines. Sketch the magnitude and phase spectra. (10+2+2=14)

Ans:

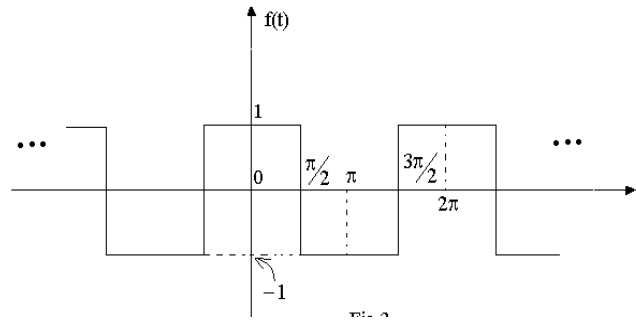

Define $g(t) = f(t) + 1$. Then the plot of $g(t)$ is as shown, below and,

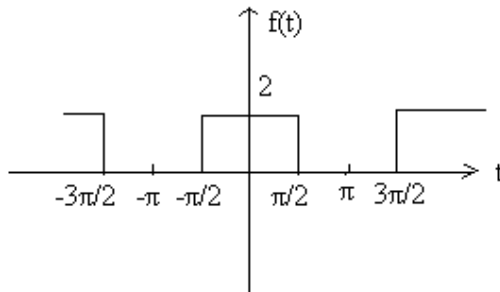

$$\omega = 2\pi/2\pi = 1$$

because $T = 2\pi$

$$g(t) = \begin{cases} 0 & -\pi < t < -\pi/2 \\ 2 & -\pi/2 < t < \pi/2 \\ 0 & \pi/2 < t < \pi \end{cases}$$

$$\text{Let } g(t) = a_0 + \sum_{n=1}^{\infty} (a_n \cos nt + b_n \sin nt)$$

Then $a_0 =$ average value of $f(t) = 1$

$$a_n = \frac{2}{2\pi} \int_{-\pi/2}^{\pi/2} 2 \cos ntdt = \frac{2}{\pi} \left. \frac{\sin nt}{n} \right|_{-\pi/2}^{\pi/2} = \frac{2}{n\pi} \cdot 2 \sin n\pi/2$$

$$= \frac{4}{n\pi} \cdot \sin n\pi/2$$

$$= \begin{cases} 0 & \text{if } n=2,4,6 \dots\dots \\ 4/n\pi & \text{if } n=1,5,9 \dots\dots \\ -4/n\pi & \text{if } n=3,7,11 \dots\dots \end{cases}$$

$$\text{Also, } b_n = \frac{2}{2\pi} \int_{-\pi/2}^{\pi/2} 2 \sin ntdt = \frac{4}{\pi} \left. \frac{\cos nt}{n} \right|_{-\pi/2}^{\pi/2} = \frac{4}{n\pi} [\cos n\pi/2 - \cos n\pi/2] = 0$$

Thus, we have $f(t) = -1 + g(t)$

$$= \frac{4 \cos t}{\pi} - \frac{4 \cos 3t}{3\pi} + \frac{4 \cos 5t}{5\pi} - \dots\dots$$

$$= \frac{4}{\pi} \{ \cos t - \cos 3t/3 + \cos 5t/5 \dots\dots \}$$

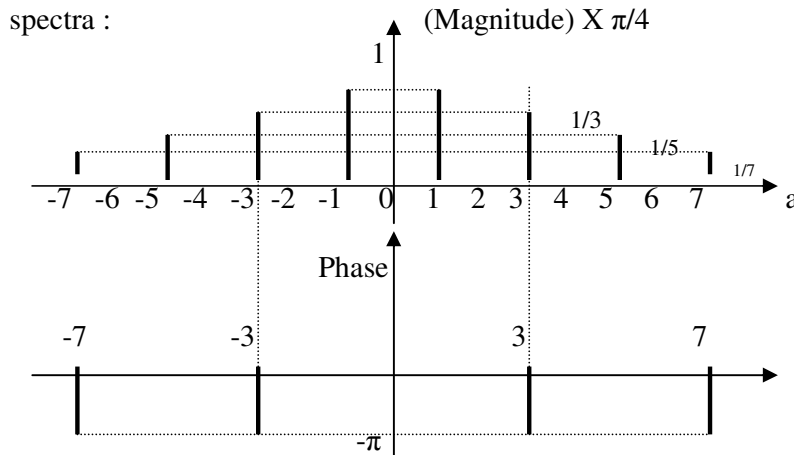

Q.40. Show that if the Fourier Transform (FT) of $x(t)$ is $X(\omega)$, then (3)

$$\text{FT} \left[\frac{dx(t)}{dt} \right] = j\omega X(\omega).$$

Ans:

$$x(t) \xleftrightarrow{\text{FT}} X(j\omega) \text{ or } X(\omega)$$

$$\text{i.e., } x(t) = \frac{1}{2\pi} \int_{-\infty}^{+\infty} X(j\omega) e^{j\omega t} d\omega$$

$$\therefore \frac{d}{dt} [x(t)] = \frac{1}{2\pi} \int_{-\infty}^{+\infty} X(j\omega) j\omega e^{j\omega t} d\omega$$

$$\therefore \frac{d}{dt} [x(t)] \xleftrightarrow{\text{FT}} j\omega X(j\omega)$$

Q.41. Show, by any method, that $\text{FT} \left[\frac{1}{2} \right] = \pi \delta(\omega)$. (2)

Ans:

$$x(t) = \frac{1}{2\pi} \int_{-\infty}^{+\infty} X(j\omega) e^{j\omega t} d\omega$$

$$x(t) = \frac{1}{2\pi} \int_{-\infty}^{+\infty} \pi \delta(\omega) e^{j\omega t} d\omega = \frac{1}{2} \quad \therefore X(j\omega) = \pi \delta(\omega)$$

$$\therefore \frac{1}{2} \xleftrightarrow{\text{FT}} \pi \delta(\omega)$$

Q.42 Find the unit impulse response, $h(t)$, of the system characterized by the relationship :

$$y(t) = \int_{-\infty}^t x(\tau) d\tau. \tag{3}$$

Ans:

$$y(t) = \int_{-\infty}^t \delta(\tau) d\tau = \begin{cases} 1, & t \geq 0 = u(t) \\ 0, & \text{otherwise} \end{cases}$$

Q.43. Using the results of parts (a) and (b), or otherwise, determine the frequency response of the system of part (c). (6)

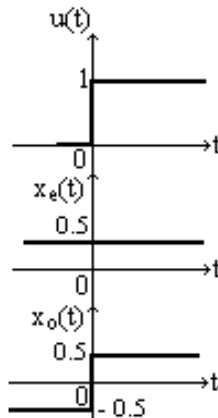

Ans:

As shown in the figure, $u(t) = 1/2 + x(t)$

$$\text{where } x(t) = \begin{cases} 0.5, & t > 0 \\ -0.5, & t < 0 \end{cases}$$

$$\therefore dx/dt = \delta(t) \text{ By (a) } \text{FT}[\delta(t)] = j\omega X(\omega)$$

$$\therefore X(\omega) = 1/j\omega. \text{ Also } \text{FT}[1/2] = \pi\delta(\omega)$$

$$\text{Therefore } \text{FT}[u(t)] = H(j\omega) = \pi\delta(\omega) + 1/j\omega.$$

Q.44. Let $X(e^{j\omega})$ denote the Fourier Transform of the signal $x(n)$ shown below. (2+2+3+5+2=14)

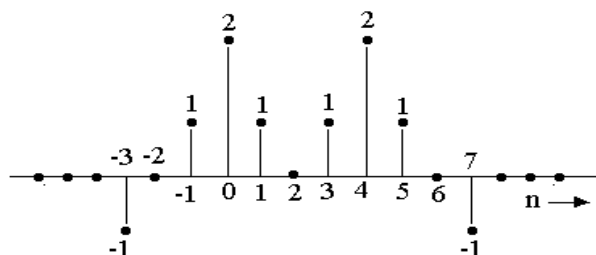

Without explicitly finding out $X(e^{j\omega})$, find the following :-

- (i) $X(1)$
- (ii) $\int_{-\pi}^{\pi} X(e^{j\omega}) d\omega$
- (iii) $X(-1)$
- (iv) the sequence $y(n)$ whose Fourier Transform is the real part of $X(e^{j\omega})$.
- (v) $\int_{-\pi}^{\pi} |X(e^{j\omega})|^2 d\omega$.

Ans:

$$X(e^{j\omega}) = \sum_{n=-\infty}^{\infty} x(n) e^{-j\omega n}$$

$$(i) X(1) = X(e^{j0}) = \sum_{n=-\infty}^{+\infty} x(n) = -1 + 1 + 2 + 1 + 1 + 2 + 1 - 1 = 6$$

$$(ii) x(n) = \frac{1}{2\pi} \int_{-\pi}^{+\pi} X(e^{j\omega}) e^{j\omega n} d\omega ; \int_{-\pi}^{\pi} X(e^{j\omega}) d\omega = 2\pi x(0) = 4\pi$$

$$(iii) X(-1) = X(e^{j\pi}) = \sum_{n=-\infty}^{+\infty} x(n) (-1)^n = 1 + 0 - 1 + 2 - 1 + 0 - 1 + 2 - 1 + 0 + 1 = 2$$

$$(iv) \text{Real part } X(e^{j\omega}) \longleftrightarrow x_e(n) = \frac{x(n) + x(-n)}{2}$$

$$y(n) = x_e(n) = 0, \quad n < -7, n > 7$$

$$y(7) = \frac{1}{2} x(7) = -\frac{1}{2} = y(-7)$$

$$y(6) = \frac{1}{2} x(6) = 0 = y(-6)$$

$$y(5) = \frac{1}{2} x(5) = \frac{1}{2} = y(-5)$$

$$y(4) = \frac{1}{2} x(4) = 2 = y(-4)$$

$$y(3) = \frac{1}{2} [x(3) + x(-3)] = 0 = y(-3)$$

$$y(2) = \frac{1}{2} [x(2) + x(-2)] = 0 = y(-2)$$

$$y(1) = \frac{1}{2} [y(1) + y(-1)] = 1 = y(-1)$$

$$y(0) = \frac{1}{2} [y(0) + y(0)] = 2$$

(v) Parseval's theorem:

$$\int_{-\pi}^{\pi} |X(e^{j\omega})|^2 d\omega = 2\pi \sum_{n=-\infty}^{\infty} |x(n)|^2 = 2\pi(1 + 1 + 4 + 1 + 1 + 4 + 1 + 1) = 28\pi$$

Q.45 If the z-transform of $x(n]$ is $X(z)$ with ROC denoted by R_x , find the

$$z\text{-transform of } y(n) = \sum_{k=-\infty}^n x(k) \text{ and its ROC.} \tag{4}$$

Ans:

$$x(n) \xleftrightarrow{z} X(z), \text{ RoC } R_x$$

$$y(n) = \sum_{k=-\infty}^n x(k) = \sum_{k=\infty}^0 x(n-k) = \sum_{k=0}^{\infty} x(n-k)$$

$$\therefore Y(z) = X(z) \underbrace{\sum_{k=0}^{\infty} z^{-k}}_{\text{Geometric series}} = \frac{X(z)}{1-z^{-1}}, \text{ RoC at least } R_x \cap (|z| > 1)$$

- Q.46** (i) $x(n)$ is a real right-sided sequence having a z -transform $X(z)$. $X(z)$ has two poles, one of which is at $a e^{j\theta}$ and two zeros, one of which is at $r e^{-j\theta}$. It is also known that $\sum x(n) = 1$. Determine $X(z)$ as a ratio of polynomials in z^{-1} . (6)
- (ii) If $a = 1/2, r = 2, \theta = \phi = \pi/4$ in part (b) (i), determine the magnitude of $X(z)$ on the unit circle. (4)

Ans:

(i) $x(n)$: real, right-sided sequence $\xleftrightarrow{z} X(z)$

$$X(z) = K \frac{(z - re^{-j\theta})(z - re^{j\theta})}{(z - ae^{j\theta})(z - ae^{-j\theta})} ; \sum x(n) = X(1) = 1$$

$$= K \frac{z^2 - zr(e^{j\theta} + e^{-j\theta}) + r^2}{z^2 - za(e^{j\theta} + e^{-j\theta}) + a^2}$$

$$= K \frac{1 - 2r \cos\theta z^{-1} + r^2 z^{-2}}{1 - 2a \cos\Phi z^{-1} + a^2 z^{-2}} = K \cdot \frac{N(z^{-1})}{D(z^{-1})}$$

where $K \cdot \frac{1 - 2r \cos\theta + r^2}{1 - 2a \cos\Phi + a^2} = X(1) = 1$

i.e., $K = \frac{1 - 2a \cos\Phi + a^2}{1 - 2r \cos\theta + r^2}$

(ii) $a = 1/2, r = 2, \theta = \Phi = \pi/4 ; K = \frac{1 - 2(1/2) \cdot (1/\sqrt{2}) + 1/4}{1 - 2(2) (1/\sqrt{2}) + 4} = 0.25$

$$X(z) = (0.25) \cdot \frac{1 - 2(2) (1/\sqrt{2}) z^{-1} + 4z^{-2}}{1 - 2(1/2) \cdot (1/\sqrt{2}) z^{-1} + 1/4 z^{-2}}$$

$$= (0.25) \frac{1 - 2\sqrt{2} z^{-1} + 4z^{-2}}{1 - (1/\sqrt{2}) z^{-1} + 1/4 z^{-2}} \implies X(e^{j\omega}) = (0.25) \frac{1 - 2\sqrt{2} e^{-j\omega} + 4 e^{-2j\omega}}{1 - (1/\sqrt{2}) e^{-j\omega} + 1/4 e^{-2j\omega}}$$

$$= \frac{-2\sqrt{2} + e^{j\omega} + 4 e^{-j\omega}}{-2\sqrt{2} + 4e^{j\omega} + e^{-j\omega}}$$

$$\therefore |X(e^{j\omega})| = 1$$

Q.47 Determine, by any method, the output $y(t)$ of an LTI system whose impulse response $h(t)$ is of the form shown in fig(a). to the periodic excitation $x(t)$ as shown in fig(b). (14)

Ans:

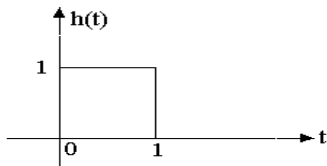

Fig(a)

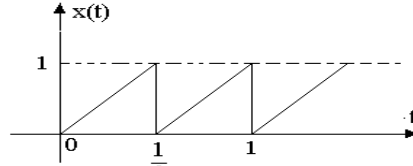

Fig(b)

$$h(t) = u(t) - u(t-1) \implies H(s) = \frac{1 - e^{-s}}{s}$$

$$\text{First period of } x(t), x_T(t) = 2t [u(t) - u(t-1/2)]$$

$$= 2[t u(t) - (t-1/2) u(t-1/2) - 1/2 u(t-1/2)]$$

$$\therefore X_T(s) = 2[1/s^2 - e^{-s/2} / s^2 - 1/2 e^{-s/2} / s]$$

$$X(s) = X_T(s) / (1 - e^{-s/2})$$

$$Y(s) = \frac{1 - e^{-s}}{s} \cdot \frac{1}{1 - e^{-s/2}} \cdot 2 \left(\frac{1 - e^{-s/2} - 0.5s e^{-s/2}}{s^2} \right)$$

$$= \frac{2}{s^3} (1 + e^{-s/2}) [1 - e^{-s/2} - 0.5s e^{-s/2}]$$

$$= \frac{2}{s^3} (1 - e^{-s} - 0.5s(e^{-s/2} + e^{-s}))$$

$$= 2 \frac{1 - e^{-s}}{s^3} - \frac{e^{-s/2} + e^{-s}}{s^2}$$

$$\text{Therefore } y(t) = t^2 u(t) - (t-1)^2 u(t-1) - \left(t - \frac{1}{2} \right) u\left(t + \frac{1}{2} \right) - (t-1)u(t-1)$$

$$\text{This gives } y(t) = \begin{cases} t^2 & 0 < t < 1/2 \\ t^2 - t + 1/2 & 1/2 < t < 1 \\ 1/2 & t > 1 \end{cases}$$

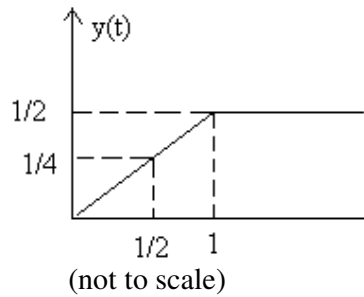

Q.48 Obtain the time function $f(t)$ whose Laplace Transform is $F(s) = \frac{s^2 + 3s + 1}{(s + 1)^3 (s + 2)^2}$. (14)

Ans:

$$F(s) = \frac{s^2 + 3s + 1}{(s + 1)^3 (s + 2)^2} = \frac{A}{(s + 1)} + \frac{B}{(s + 1)^2} + \frac{C}{(s + 1)^3} + \frac{D}{(s + 2)} + \frac{E}{(s + 2)^2}$$

$$A(s + 2)^2 (s + 1)^2 + B(s + 2)^2 (s + 1) + C(s + 2)^2 + D(s + 1)^3 (s + 2) + E(s + 1)^3 = s^2 + 3s + 1$$

$$C = \frac{s^2 + 3s + 1}{(s + 2)^2} \Big|_{s = -1} = \frac{1 - 3 + 1}{1} = -1 \quad \text{C} = -1$$

$$E = \frac{s^2 + 3s + 1}{(s + 1)^3} \Big|_{s = -2} = \frac{4 - 6 + 1}{-1} = 1 \quad \text{E} = 1$$

$$A(s^2 + 3s + 2)^2 + B(s^2 + 4s + 4)(s + 1) + C(s^2 + 4s + 4) + D(s^3 + 3s^2 + 3s + 1)(s + 2) + E(s^3 + 3s^2 + 3s + 1) = s^2 + 3s + 1$$

$$A(s^4 + 6s^3 + 13s^2 + 12s + 4) + B(s^3 + 5s^2 + 8s + 4) + C(s^2 + 4s + 4) + D(s^4 + 5s^3 + 9s^2 + 7s + 2) + E(s^3 + 3s^2 + 3s + 1) = s^2 + 3s + 1$$

$$s^4 : A + D = 0$$

$$s^3 : 6A + B + 5D + E = 0 \quad ; \quad A + B + 1 = 0 \quad \text{as } 5(A + D) = 0, E = 1$$

$$s^2 : 13A + 5B + C + 9D + 3E = 1 \quad ; \quad 4A + 5B + 1 = 0 \quad \text{as } 9(A + D) = 0, C = -1, E = 1$$

$$s^1 : 12A + 8B + 4C + 7D + 3E = 3 \quad ; \quad 5A + 8B - 4 = 0 \quad \text{as } 7(A + D) = 0, C = -1, E = 1$$

$$s^0 : 4A + 4B + 4C + 2D + E = 1$$

$$A + B = -1 \quad ; \quad 4(A + B) + B + 1 = 0 \quad \text{or} \quad -4 + B + 1 = 0 \quad \text{or}$$

$$A = -4 \quad \text{B} = 3$$

$$\therefore A = -1 - 3 = -4$$

$$A + D = 0 \quad \text{or} \quad D = -A = 4 \quad \text{D} = 4$$

$$\therefore F(s) = \frac{-4}{(s + 1)} + \frac{3}{(s + 1)^2} + \frac{-1}{(s + 1)^3} + \frac{4}{(s + 2)} + \frac{1}{(s + 2)^2}$$

$$\therefore f(t) = L^{-1}[F(s)] = -4e^{-t} + 3te^{-t} - \frac{1}{2}t^2e^{-t} + 4e^{-2t} + te^{-2t} = [e^{-t}(-4 + 3t - \frac{1}{2}t^2) + e^{-2t}(4 + t)] u(t)$$

$$\therefore f(t) = [e^{-t}(-4 + 3t - t^2) + e^{-2t}(4 + t)] u(t)$$

Q.49 Define the terms variance, co-variance and correlation coefficient as applied to random variables. (6)

Ans:

Variance of a random variable X is defined as the second central moment

$E[(X-\mu_X)]^n$, $n=2$, where central moment is the moment of the difference between a random variable X and its mean μ_X i.e.,

$$\sigma_X^2 = \text{var} [X] = \int_{-\infty}^{+\infty} (x - \mu_X)^2 f_X(x) dx$$

Co-variance of random variables X and Y is defined as the joint moment:

$$\sigma_{XY} = \text{cov} [XY] = E[\{X-E[X]\} \{Y-E[Y]\}] = E[XY] - \mu_X \mu_Y$$

where $\mu_X = E[X]$ and $\mu_Y = E[Y]$.

Correlation coefficient ρ_{XY} of X and Y is defined as the co-variance of X and Y normalized w.r.t $\sigma_X \sigma_Y$:

$$\rho_{XY} = \frac{\text{cov} [XY]}{\sigma_X \sigma_Y} = \frac{\sigma_{XY}}{\sigma_X \sigma_Y}$$

Q.50 Determine the total energy of the raised-cosine pulse $x(t)$, shown in Fig.1 defined by: (8)

$$x(t) = \begin{cases} \frac{1}{2}(\cos \omega t + 1), & -\frac{\pi}{\omega} \leq t \leq \frac{\pi}{\omega} \\ 0, & \text{otherwise} \end{cases}$$

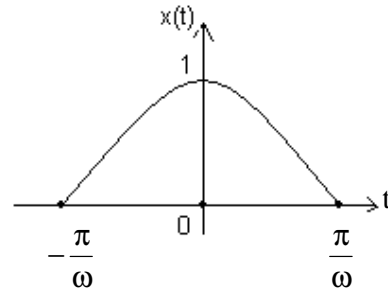

Fig.1

Ans:

$$\text{Energy } E = \int_{-\infty}^{+\infty} x^2(t) dt = \int_{-\frac{\pi}{\omega}}^{\frac{\pi}{\omega}} \frac{1}{4} (\cos \omega t + 1)^2 dt = \frac{3\pi}{4\omega} \text{ units.}$$

Q.51 State the sampling theorem, given $x(t) \leftrightarrow X(\omega)$. For the spectrum of the continuous-time signal, shown in Fig.2, consider the three cases $f_s = 2f_x$; $f_s > 2f_x$; $f_s < 2f_x$ and draw the spectra, indicating aliasing. (8)

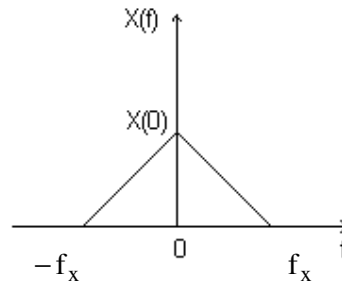
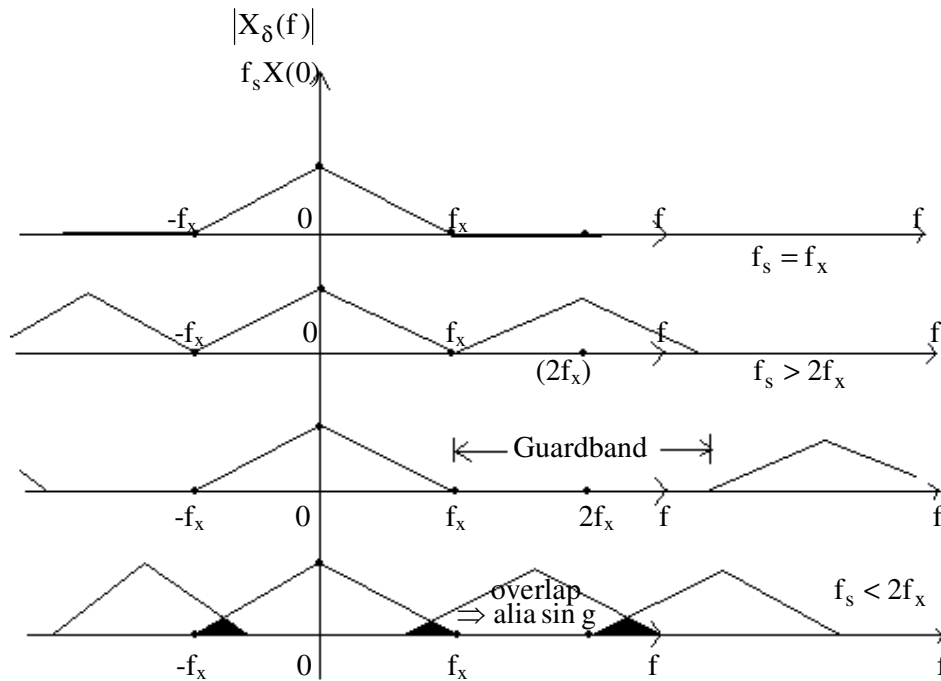

Fig.2

Ans:

Sampling theorem: Given $x(t) \leftrightarrow X(\omega)$, if $X(\omega) = 0$ for $|\omega| > \omega_m$, and if $\omega_s > 2\omega_m$, where sampling frequency $\omega_s = \frac{2\pi}{T_s}$, $T_s =$ Sampling interval, then $x(t)$ is uniquely determined by its samples $x(nT_s) \rightarrow$ where $n = 0, \pm 1, \pm 2, \dots$ ($\omega_s > 2\omega_m \Rightarrow$ Nyquist rate.)



Q.52 Consider a continuous-time signal $x(t)$. (8)

- (i) Show that $X(t) \leftrightarrow 2\pi x(-\omega)$, using duality (or similarity) property of FT s.
- (ii) Find $x(t)$ from $X(\omega) = \frac{1}{(1 + j\omega)^2}$, using the convolution property of FTs.

Ans:

(i)
$$x(t) = \frac{1}{2\pi} \int_{\omega=-\infty}^{+\infty} X(\omega) e^{j\omega t} d\omega$$

Using duality property of FTs, $t \leftrightarrow \omega$,

$$x(\omega) = \frac{1}{2\pi} \int_{t=-\infty}^{+\infty} X(t)e^{j\omega t} dt, \text{ or, } x(-\omega) = \frac{1}{2\pi} \int_{t=-\infty}^{+\infty} X(t)e^{-j\omega t} dt$$

$$\therefore 2\pi x(-\omega) = \int_{-\infty}^{+\infty} X(t)e^{-j\omega t} dt, \text{ i.e., } X(t) \xleftrightarrow{\text{FT}} 2\pi x(-\omega).$$

(ii) Find $x(t)$ from $X(\omega) = \frac{1}{(1+j\omega)^2}$, using the convolution property of FTs.

$$X(\omega) = \frac{1}{(1+j\omega)^2} = \frac{1}{1+j\omega} \cdot \frac{1}{1+j\omega}, \text{ and, } e^{-t}u(t) \xleftrightarrow{\text{FT}} \frac{1}{1+j\omega}.$$

Convolution property of FTs $\Rightarrow x(t) = x_1(t) * x_2(t) \xleftrightarrow{\text{FT}} X(\omega) = X_1(\omega)X_2(\omega).$

$$\therefore x(t) = \int_{-\infty}^{+\infty} e^{-\tau}u(\tau)e^{-(t-\tau)}u(t-\tau)d\tau. \quad u(\tau)u(t-\tau) = \begin{cases} 1, & 0 < \tau < t < 0 \\ 0, & t < 0. \end{cases}$$

$$= t \cdot e^{-t}, t > 0$$

$$\therefore x(t) = t e^{-t}u(t).$$

Q.53 Find the difference equation describing the system represented by the block-diagram shown in Fig.3, where D stands for unit delay. (8)

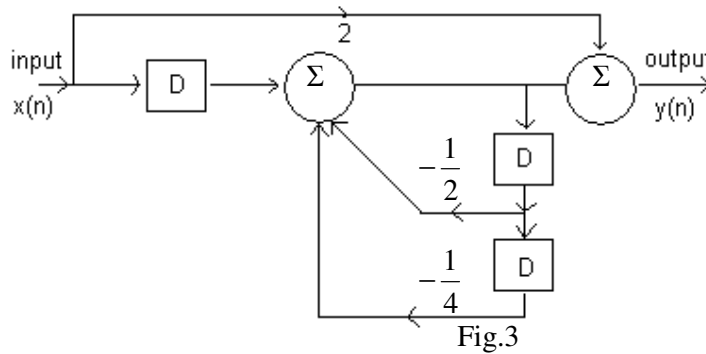

Ans:

Intermediate variable $f(n)$ between the summers:

$$f(n) = x(n-1) - \frac{1}{2}f(n-1) - \frac{1}{4}f(n-2)$$

$$y(n) = 2x(n) + f(n), \text{ or, } f(n) = y(n) - 2x(n)$$

$$f(n-1) = y(n-1) - 2x(n-1)$$

$$f(n-2) = y(n-2) - 2x(n-2)$$

$$y(n) + \frac{1}{2}y(n-1) + \frac{1}{4}y(n-2) = 2x(n) + 2x(n-1) + \frac{1}{2}x(n-2).$$

Q.54 For the simple continuous-time RC frequently-selective filter shown in Fig.4, obtain the frequency response $H(\omega)$. Sketch its magnitude and phase for $-\infty < \omega < \infty$. (8)

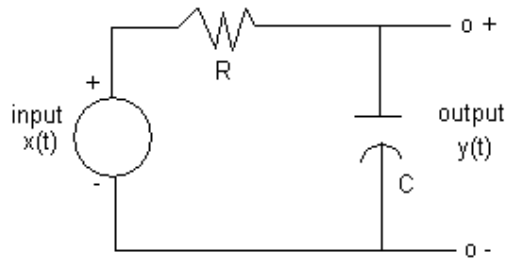

Fig.4

Ans:

$$\text{KVL} \Rightarrow x(t) = RC \frac{dy(t)}{dt} + y(t) \xleftrightarrow{\text{FT}} X(\omega) = RCj\omega Y(\omega) + Y(\omega)$$

$$\text{or, } H(\omega) = \frac{Y(\omega)}{X(\omega)} = \frac{1}{1 + j\omega CR} = \frac{1}{1 + j\left(\frac{\omega}{\omega_0}\right)}$$

$$|H(\omega)| = \frac{1}{\sqrt{1 + \left(\frac{\omega}{\omega_0}\right)^2}}$$

$$\arg H(\omega) = -\tan^{-1}\left(\frac{\omega}{\omega_0}\right)$$

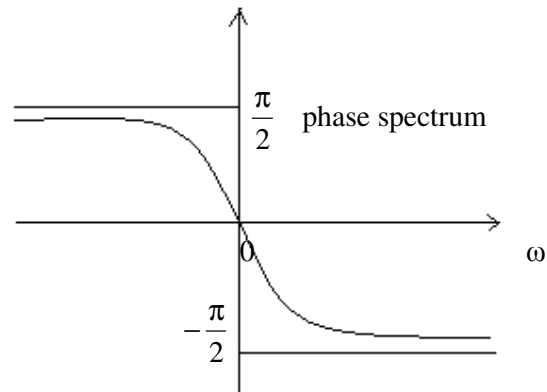
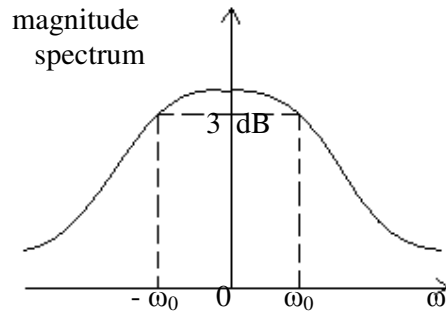

Q.55 Consider the signal $x(t) = e^{-t}u(t) + e^{-2t}u(t)$. Express its Laplace Transform in the form: $X(s) = K \frac{N(s)}{D(s)}$, K = system constant. Identify the region of convergence. Indicate poles and zeros in the s-plane. (8)

Ans:

$$x(t) = e^{-t}u(t) + e^{-2t}u(t) \xleftrightarrow{\text{L}} X(s) = \frac{1}{s+1} + \frac{1}{s+2}$$

$$X(s) = \frac{2s+3}{(s+1)(s+2)} = 1 \frac{\left(s + \frac{3}{2}\right)}{\left(s^2 + 3s + 2\right)} = K \frac{N(s)}{D(s)}, K = 2.$$

1 Zero $\Rightarrow s = -\frac{3}{2}$.
 2 Poles $\Rightarrow s = -1, -2$.
 ROC $\Rightarrow \text{Re}\{s\} > -1$.
 $\text{Re}\{s\} > -2$.
 \therefore Common ROC is $\text{Re}\{s\} > -1$.

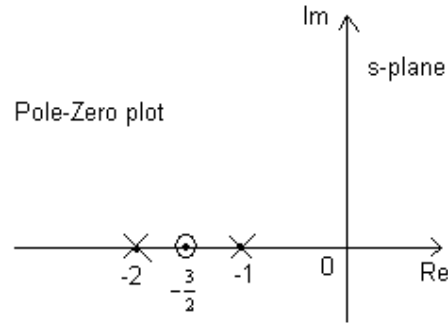

Q.56 Given input $x(n)$ and impulse response $h(n)$, as shown in Fig.5, evaluate $y(n) = x(n) * h(n)$, using DTFTs. (8)

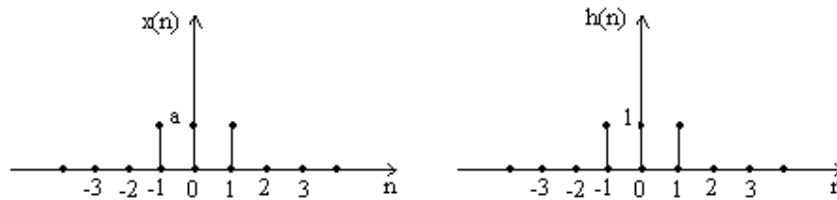

Fig.5

Ans:

$$y(n) = x(n) * h(n) \leftrightarrow Y(e^{j\Omega}) \cdot H(e^{j\Omega})$$

$$H(e^{j\Omega}) = e^{+j\Omega} + 1 + e^{-j\Omega} \quad ; \quad X(e^{j\Omega}) = ae^{+j\Omega} + a + ae^{-j\Omega}$$

$$\therefore Y(e^{j\Omega}) = a(e^{j\Omega} + 1 + e^{-j\Omega})^2 = a(e^{-j2\Omega} + 2e^{j\Omega} + 3 + 2e^{-j\Omega} + e^{-j2\Omega})$$

As $\delta(n - n_0) \leftrightarrow e^{-j\Omega n_0}$, $y(n) = a\delta(n+2) + 2a\delta(n+1) + 3a\delta(n) + 2a\delta(n-1) + a\delta(n-2)$.

$$y(n) = \{a, 2a, 3a, 2a, a\}$$

\uparrow
 $n = 0$

Q.57 Determine the inverse DTFT, by partial fraction expansion, of

$$X(e^{j\Omega}) = \frac{6}{e^{-j2\Omega} - 5e^{-j\Omega} + 6} \quad (8)$$

Ans:

$$X(e^{j\Omega}) = \frac{6}{(e^{-j\Omega})^2 - 5(e^{-j\Omega}) + 6} = \frac{6}{(e^{-j\Omega} - 3)(e^{-j\Omega} - 2)} = \frac{-2}{1 - \frac{1}{3}e^{-j\Omega}} + \frac{3}{1 - \frac{1}{2}e^{-j\Omega}}$$

$$\therefore x(n) = -2\left(\frac{1}{3}\right)^n u(n) + 3\left(\frac{1}{2}\right)^n u(n) = \left[-2\left(\frac{1}{3}\right)^n + 3\left(\frac{1}{2}\right)^n\right] u(n)$$

Q.58 State the initial-value and final-value theorems of Laplace Transforms. Compute the initial-value and final-values for $x(t) \leftrightarrow X(s)$, where $x(s) = \frac{3s + 4}{s(s+1)(s+2)^2}$. (8)

Ans:

Initial-value theorem: If $f(t)$ and its first derivative are Laplace transformable, then the initial value of $f(t)$ is: $f(0^+) = \lim_{t \rightarrow 0^+} f(t) = \lim_{s \rightarrow \infty} sF(s)$.

Final-value theorem: If $f(t)$ and its first derivative are Laplace transformable, and $f(t)$ is not a periodic function, then the final value of $f(t)$ is: $\lim_{t \rightarrow \infty} f(t) = \lim_{s \rightarrow 0} sF(s)$.

$$\text{Initial value} \Rightarrow x(0^+) = \lim_{s \rightarrow \infty} sX(s) = \lim_{s \rightarrow \infty} \frac{\left(3 + \frac{4}{s}\right)}{\left(1 + \frac{1}{s}\right)(s+2)^2} = 0.$$

$$\text{Final value} \Rightarrow \lim_{t \rightarrow \infty} x(t) = \lim_{s \rightarrow 0} sX(s) = \lim_{s \rightarrow 0} \frac{(3s+4)}{(s+1)(s+2)^2} = 1.$$

Q.59 Find, by Laplace Transform method, the output $y(t)$ of the system described by the differential equation: $\frac{dy(t)}{dt} + 5y(t) = x(t)$ where input $x(t) = 3e^{-2t}u(t)$ and the initial condition is $y(0) = -2$. (8)

Ans:

$$\frac{dy(t)}{dt} + 5y(t) = 3e^{-2t}u(t), \quad y(0) = -2.$$

$$y(t) \leftrightarrow Y(s), \quad u(t), e^{-2t} \leftrightarrow \frac{1}{s+2}.$$

$$\therefore sY(s) - y(0^+) + 5Y(s) = \frac{3}{s+2}.$$

$$Y(s) = \frac{3}{(s+2)(s+5)} + \frac{-2}{(s+5)} = \frac{A}{s+2} + \frac{B}{s+5} - \frac{2}{s+5}.$$

$$= \frac{1}{s+2} - \frac{3}{s+5}, \quad A = \frac{3}{s+5} \Big|_{s=-2} = 1$$

$$\therefore y(t) = \left(e^{-2t} - 3e^{-5t} \right) u(t), \quad B = \frac{3}{s+2} \Big|_{s=-5} = -1.$$

Q.60 An LTI system is characterised by the difference equation: $x(n-2) - 9x(n-1) + 18x(n) = 0$ with initial conditions $x(-1) = 1$ and $x(-2) = 9$. Find $x(n)$ by using z-transform and state the properties of z-transform used in your calculation. (8)

Ans:

$$x(n-2) - 9x(n-1) + 18x(n) = 0$$

By using

$$x(n-n_0) \leftrightarrow z^{-n_0}X(z) + x(-n_0) + z^{-1}x(-n_0+1) + z^{-2}x(-n_0+2) + \dots + z^{-(n_0-1)}x(-1)$$

We get $\underbrace{[x(-2) + x(-1)]}_9 z^{-1} + z^{-2}X(z) - 9\underbrace{[x(-1) + z^{-1}X(z)]}_1 + 18X(z) = 0$.

$$X(z) = \frac{-z^{-1}}{18\left(1 - \frac{1}{2}z^{-1} + \frac{1}{18}z^{-2}\right)} = \frac{z^{-1}}{18} \left(\frac{1}{1 - \frac{1}{6}z^{-1}} - \frac{2}{1 - \frac{1}{3}z^{-1}} \right)$$

$$\therefore x(n) = \frac{1}{18} \left[\left(\frac{1}{16}\right)^{n-1} - 2\left(\frac{1}{3}\right)^{n-1} \right] u(n-1)$$

Q.61 Determine the discrete-time sequence $x(n]$, given that $x(n) \stackrel{z}{\leftrightarrow} X(z) = \frac{z^2 + z}{z^3 - 3z^2 + 3z - 1}$. (8)

Ans: Assume that $x(n]$ is casual. Then

$$\begin{aligned} z^3 - 3z^2 + 3z - 1 & \left[\begin{array}{l} z^2 + z \\ z^{-1} + 4z^{-2} + 9z^{-3} + 16z^{-4} + \dots \end{array} \right] \\ & \frac{z^2 - 3z + 3 - z^{-1}}{4z - 3 + z^{-1}} \\ & \frac{4z - 12 + 12z^{-1} - 4z^{-2}}{9 - 11z^{-1} + 4z^{-2}} \\ & \frac{9 - 27z^{-1} + 27z^{-2} - 9z^{-3}}{16z^{-1} - 23z^{-2} + 9z^{-3}} \\ & \frac{16z^{-1} - 48z^{-2} + 48z^{-3} - 16z^{-4}}{25z^{-2} - 39z^{-3} + 16z^{-4}} \\ \therefore X(z) & = z^{-1} + 4z^{-2} + 9z^{-3} + 16z^{-4} + \dots \quad \left[\delta(n - n_0) \stackrel{z}{\leftrightarrow} z^{-n_0} \right] \\ \therefore x(n) & = \delta(n - 1) + 4\delta(n - 2) + 9\delta(n - 3) + 16\delta(n - 4) + \dots \\ x(n) & = \{0, 1, 4, 9, 16, \dots\} \\ & \quad \uparrow \\ & \quad n = 0 \end{aligned}$$

Q.62 Explain the meaning of the following terms with respect to random variables/processes:

- (i) Wide-sense stationary process.
- (ii) Ergodic process.
- (iii) White noise.
- (iv) Cross power spectral density. (8)

Ans:

(i) Wide-sense stationary process.
For stationary processes, means and variances are independent of time, and covariance depends only on the time-difference if in addition, the N-fold joint p.d.f. depends on the time origin, such a random process is called wide- sense stationary process.

(ii) Ergodic process.
Ergodic process is one in which time and ensemble averages are interchangeable.

For ergodic processes, all time and ensemble averages are interchangeable, not just the mean, variance and autocorrelation function.

(iii) White noise.

White noise is an idealised form of noise, the power spectral density of which is independent of frequency. “White” is in parlance with white light that contains all frequencies within the visible band of electromagnetic radiation..

(iv) Cross power spectral density.

Cross power spectral density of two stationary random processes is defined as the FT of their cross-correlation function

$$R_{xy}(\tau) \leftrightarrow S_{xy}(f), \text{ where, } R_{xy}(\tau) = E\{X(t).Y(t+\tau)\}.$$

Q.63 A random variable X is characterised by probability density function shown in Fig.6:

$$f_X(x) = \begin{cases} 1 - \frac{x}{2}, & 0 \leq x \leq 2 \\ 0, & \text{otherwise} \end{cases}$$

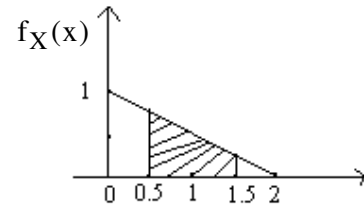

Compute its: Probability distribution function;
 Probability in the range $0.5 < x \leq 1.5$;
 Mean value between $0 \leq x \leq 2$; and
 Mean-square value $E(x^2)$.

Fig.6 (8)

Ans:

$$\text{p.d.f. } f_X(x) = \int_{-\infty}^{+\infty} f_X(\alpha) d\alpha = \int_0^x \left(1 - \frac{\alpha}{2}\right) d\alpha = x - \frac{x^2}{4}, \quad 0 < x \leq 2.$$

$$\text{Probability} = f_X(1.5) - f_X(0.5) = \frac{1}{2}.$$

$$(0.5 < X \leq 1.5)$$

$$\text{Mean value } m_X = \int_0^2 x \left(1 - \frac{x}{2}\right) dx = \frac{2}{3}$$

$$\text{Mean-squared value } E[x^2] = \int_0^2 x^2 \left(1 - \frac{x}{2}\right) dx = \frac{2}{3}.$$

Q.64 Determine the fundamental frequency of the signal

$$x[n] = e^{-j4\pi n/3} + e^{j3\pi n/8}.$$

Ans:

$$x(n) = e^{\frac{-j4\pi n}{3}} + e^{\frac{-j3\pi n}{8}} = e^{\frac{-j32\pi n}{24}} + e^{\frac{-j9\pi n}{24}}$$

$$\text{Fundamental Frequency} = \frac{1}{24}.$$

Q.65 A CT system is described by $y(t) = \int_{-\infty}^{t/3} x(\lambda) d\lambda$. Find if the system is time invariant and stable. (6)

Ans:

$$y(t) = \int_{-\infty}^{\frac{t}{3}} x(\lambda) d\lambda.$$

Let $x(t)$ be shifted by t_0 then the corresponding output $y_i(t)$ will be

$$y_i(t) = \int_{-\infty}^{\frac{t}{3}} x(\lambda - t_0) d\lambda = \int_{-\infty}^{\frac{t}{3} - t_0} x(\lambda') d\lambda' \text{ where } \lambda' = \lambda - t_0.$$

Original output shifted by t_0 sec is

$$y_o(t) = \int_{-\infty}^{\frac{t-t_0}{3}} x(\lambda) d\lambda$$

Hence the system is time-invariant.

If $x(t)$ is bounded, output will be bounded. Hence the system is stable.

Q.66

Let $x(t)$ be a real signal and $x(t) = x_1(t) + x_2(t)$. Find a condition so that

$$\int_{-\infty}^{\infty} |x(t)|^2 dt = \int_{-\infty}^{\infty} |x_1(t)|^2 dt + \int_{-\infty}^{\infty} |x_2(t)|^2 dt \quad (6)$$

Ans: $\int_{-\infty}^{\infty} |x(t)|^2 dt = \int_{-\infty}^{\infty} (|x_1(t)| + |x_2(t)|)^2 dt$

$$\int_{-\infty}^{\infty} |x(t)|^2 dt = \int_{-\infty}^{\infty} |x_1(t)|^2 dt + \int_{-\infty}^{\infty} |x_2(t)|^2 dt + 2 \int_{-\infty}^{\infty} |x_1(t)||x_2(t)| dt$$

The term $2 \int_{-\infty}^{\infty} |x_1(t)||x_2(t)| dt$ will become zero if $x_1(t)$ is the even part and $x_2(t)$

is the odd part of $x(t)$ or vice-versa. Then

$$\int_{-\infty}^{\infty} |x(t)|^2 dt = \int_{-\infty}^{\infty} |x_1(t)|^2 dt + \int_{-\infty}^{\infty} |x_2(t)|^2 dt.$$

Q.67

If $h_1[n] = \delta[n]$, $h_2[n] = \delta[n-1] + 2\delta[n-2]$, $h_3[n] = \delta[n+1] + 2\delta[n+2]$ are the impulse responses of three LTI systems, determine the impulse response of the system shown in Fig.1.

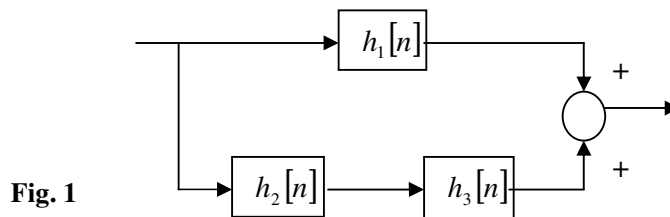

Ans:

$$h_1(n) = \delta(n)$$

$$h_2(n) = \delta(n-1) + 2\delta(n-2)$$

$$h_3(n) = \delta(n+1) + 2\delta(n+2)$$

Impulse response of the system,

$$\begin{aligned} h(n) &= h_1(n) + h_2(n) * h_3(n) \\ &= \delta(n) + 2\delta(n+1) + 5\delta(n) + 2\delta(n-1) \\ &= 6\delta(n) + 2\delta(n+1) + 2\delta(n-1). \end{aligned}$$

Q.68 Given that $y(t) = x(t) * h(t)$, determine $x(at) * h(at)$ in terms of $y(t)$. If a is real, for what values of a the system will be (i) causal, (ii) stable? **(10)**

Ans: $y(t) = x(t) * h(t)$

Thus, $Y(s) = X(s)H(s)$

Now $x(at)$ has Laplace transform $(1/a) X(s/a)$. Similarly $h(at)$ has Laplace transform $(1/a) H(s/a)$. Thus

$$\begin{aligned} \text{Laplace transform of } x(at) * h(at) &= (1/a^2) X(s/a) H(s/a) \\ &= (1/a) (1/a) Y(s/a) \\ &= \text{Laplace transform of } (1/a)y(at) \end{aligned}$$

Assuming the original system to be causal and stable,

- (i) to maintain only causality, a can take any value,
- (ii) to maintain stability, $a > 0$.

Q.69 One period of a continuous-time periodic signal $x(t)$ is as given below.

$$x(t) = \begin{cases} |t|, & -1 < t < 1 \\ 0, & 1 < t < 2 \end{cases} \quad \text{(10)}$$

Determine Fourier series coefficients of $x(t)$, assuming its period to be 3.

Ans: $x(t) = \begin{cases} |t|, & -1 < t < 1 \\ 0, & 1 < t < 2 \end{cases}$

$$a_0 = \frac{1}{T} \left\{ \int_{-1}^0 -t dt + \int_0^1 t dt \right\} = \frac{1}{T} \left\{ \left[-\frac{t^2}{2} \right]_{-1}^0 + \left[\frac{t^2}{2} \right]_0^1 \right\} = \frac{1}{T}$$

$$\begin{aligned} a_k &= \frac{1}{T} \left\{ \int_T x(t) e^{-jk\omega_0 t} dt \right\} = \frac{1}{T} \left\{ \int_{-1}^0 -t e^{-jk\omega_0 t} dt + \int_0^1 t e^{-jk\omega_0 t} dt \right\} \\ &= \frac{1}{T} \left\{ \left[\frac{e^{jk\omega_0}}{jk\omega_0} + \frac{e^{jk\omega_0} - 1}{k^2\omega_0^2} \right] + \left[-\frac{e^{-jk\omega_0}}{jk\omega_0} + \frac{e^{-jk\omega_0} - 1}{k^2\omega_0^2} \right] \right\} \\ &= \frac{1}{T} \left\{ \frac{2}{k\omega_0} \left[\frac{e^{jk\omega_0} - e^{-jk\omega_0}}{2j} \right] + \left[\frac{2}{k^2\omega_0^2} \left[\frac{e^{jk\omega_0} + e^{-jk\omega_0}}{2} - 1 \right] \right] \right\} \\ &= \frac{2}{T} \left\{ \frac{\sin k\omega_0}{k\omega_0} + \frac{\cos k\omega_0 - 1}{k^2\omega_0^2} \right\} \\ &= \left\{ \frac{\sin 2\pi k / T}{\pi k} + T \frac{\cos 2\pi k / T - 1}{2\pi^2 k^2} \right\} \end{aligned}$$

$$a_0|_{T=3} = \frac{1}{3}$$

$$a_k|_{T=3} = \left\{ \frac{\sin 2\pi k / 3}{\pi k} + 3 \frac{\cos 2\pi k / 3 - 1}{2\pi^2 k^2} \right\}$$

Q.70 Determine Fourier series coefficients of the same signal $x(t)$ as in Q69, but now, assuming its period to be 6. What is the relationship between the coefficients determined in Q69 & Q70? **(6)**

Ans: Let the period be $T_2 = 2T_1 = 6$. Following the above procedure, we get

$$a_{02} = \frac{1}{T_2} \left\{ \int_{-2}^0 -t dt + \int_0^2 t dt \right\} = \frac{4}{T_2} = \frac{2}{T_1} = 2a_{01}$$

$$a_{k2} = \frac{1}{T_2} \left\{ \int_{-2}^0 -t e^{-jk\omega_0 t} dt + \int_0^2 t e^{-jk\omega_0 t} dt \right\}$$

$$= 2 \left\{ \frac{\sin 4\pi k / T_2}{\pi k} + T_2 \frac{\cos 4\pi k / T_2 - 1}{4\pi^2 k^2} \right\}$$

$$= 2 \left\{ \frac{\sin 2\pi k / T_1}{\pi k} + T_1 \frac{\cos 2\pi k / T_1 - 1}{2\pi^2 k^2} \right\} = 2a_{k1}$$

Thus the Fourier coefficients are doubled when the period is doubled. The function with higher period will have all the harmonics present in the lower period function as even harmonics.

Q.71 The Fourier transform of a signal $x(t)$ is described as

$$|X(j\omega)| = \begin{cases} |\omega|, & -1 < \omega < 1 \\ 0, & \text{otherwise} \end{cases} \quad \text{and} \quad \arg X(j\omega) = \begin{cases} 0.5\pi & -1 < \omega < 0 \\ -0.5\pi & 0 < \omega < 1 \\ 0 & \text{otherwise} \end{cases}$$

Determine whether $x(t)$ is real or complex.

Ans: The magnitude response is symmetric and the phase response is anti-symmetric. So $x(t)$ is real.

Q.72 Determine the inverse Fourier transform of $X(j\omega) = \frac{4}{\omega^2} \sin^2 \omega$ using the convolution property of the Fourier transform. (4)

$$\mathbf{Ans:} X(j\omega) = \frac{4}{\omega^2} \sin^2 \omega = \left(\frac{2}{\omega} \sin \omega \right) \left(\frac{2}{\omega} \sin \omega \right) = P(j\omega) \cdot P(j\omega)$$

Multiplication in the frequency domain is equivalent to convolution in the time domain.

Inverse Fourier transform of $P(j\omega) = 2 \frac{\sin \omega}{\omega}$ is a pulse

$$p(t) = \begin{cases} 1, & |t| \leq 1 \\ 0, & |t| > 1. \end{cases}$$

Therefore

$$x(t) = p(t) * p(t) = \begin{cases} 2 - |t|, & |t| \leq 2 \\ 0, & |t| > 2 \end{cases}$$

Q.73 A system is described by the difference equation $y[n] = x[n] + ay[n-1]$. Find the impulse response of the inverse of this system. From the impulse response, find the difference equation of the inverse system. (8)

$$\mathbf{Ans:} y[n] = x[n] + ay[n-1]$$

$$H(z) = \frac{Y(z)}{X(z)} = \frac{1}{1 - az^{-1}}$$

For Inverse System:

Transfer function $H_1(z) = \frac{1}{H(z)} = 1 - az^{-1}$

Impulse Response: $h_1(n) = 1\delta(n) - a\delta(n-1)$

Difference equation: $y(n) = x(n) - ax(n-1)$

Q.74 Determine the autocorrelation of the sequence $\{1, 1, 2, 3\}$. (8)

Ans: $x(n) = (1, 1, 2, 3)$

Since $r_{xx}(k) = \sum_{m=-\infty}^{\infty} x(m)x(m-k) = r_{xx}(-k)$

$$r(0) = x(0)x(0) + x(1)x(1) + x(2)x(2) + x(3)x(3) = 15$$

$$r(1) = x(0)x(1) + x(1)x(2) + x(2)x(3) = 9 = r(-1)$$

$$r(2) = x(0)x(2) + x(1)x(3) = 5 = r(-2)$$

$$r(3) = x(0)x(3) + x(1)x(3) = 3 = r(-3)$$

$$r(\geq 4) = 0$$

Thus

$$r(n) = [3, 5, 9, 15, 9, 5, 3]$$

↑

Q.75 Determine the cross correlation of the processes $x_1(t) = A \cos(2\pi f_c t + \theta)$ and $x_2(t) = B \sin(2\pi f_c t + \theta)$, where θ is an independent random variable uniformly distributed over the interval $(0, 2\pi)$. (8)

Ans: $x_1(t) = A \cos(2\pi f_c t + \theta)$ and $x_2(t) = B \sin(2\pi f_c t + \theta)$

$$R_{xx}(\tau) = E\{A \cos\{2\pi f_c(t + \tau) + \theta\} B \sin(2\pi f_c t + \theta)\}$$

$$= \frac{AB}{2} E[\sin\{2\pi f_c(-\tau)\} + \sin\{2\pi f_c(2t + \tau + 2\theta)\}]$$

$$= -\frac{AB}{2} \sin(2\pi f_c \tau) + \frac{AB}{2} \frac{1}{2\pi} \int_{-\pi}^{\pi} \sin\{2\pi f_c(2t + \tau + 2\theta)\} d\theta$$

$$= -\frac{AB}{2} \sin(2\pi f_c \tau)$$

Q.76 A signal $x(t) = \frac{\sin \pi t}{\pi}$ is sampled by $p(t) = \sum_{n=-\infty}^{\infty} \delta\left(t - \frac{n}{2}\right)$. Determine and sketch the sampled signal and its Fourier transform. (8)

Ans: $x(t) = \frac{\sin \pi t}{\pi}$ sampled by $p(t) = \sum_{n=-\infty}^{\infty} \delta\left(t - \frac{n}{2}\right)$. Thus, the sampled signal is

$$x(n) = \frac{\sin \pi \left(\frac{n}{2}\right)}{\pi \left(\frac{n}{2}\right)}$$

DTFT of $x(n)$ is a pulse

$$X(\omega) = \begin{cases} 2, & |\omega| \leq \frac{\pi}{2} \\ 0, & \text{otherwise} \end{cases}$$

Q.77 Determine the Fourier transforms of (8)

(i) $x_1[n] = \sin n\omega_0$ and (ii) $x_2[n] = (\sin n\omega_0)u[n]$

Ans: (i) $x_1[n] = \sin n\omega_0 = \frac{e^{j\omega_0 n} - e^{-j\omega_0 n}}{2j} = \frac{1}{2j} [e^{j\omega_0 n} - e^{-j\omega_0 n}]$

$$X(\omega) = \frac{1}{2j} [\delta(\omega + \omega_0) - \delta(\omega - \omega_0)]$$

(ii) $x_2[n] = (\sin n\omega_0)u(n) = \frac{e^{j\omega_0 n}u(n) - e^{-j\omega_0 n}u(n)}{2j}$

$$\begin{aligned} X(\omega) &= \frac{1}{2j} \left[\frac{1}{1 - e^{j\omega_0} e^{-j\omega}} - \frac{1}{1 - e^{-j\omega_0} e^{-j\omega}} \right] \\ &= \frac{1}{2j} e^{j\omega} \left[\frac{1}{e^{j\omega} - e^{j\omega_0}} - \frac{1}{e^{j\omega} - e^{-j\omega_0}} \right] \\ &= e^{j\omega} \left[\frac{\sin \omega_0}{1 + e^{j2\omega} - 2e^{j\omega} \cos \omega_0} \right] \\ &= \frac{1}{2} \left[\frac{\sin \omega_0}{\cos \omega - \cos \omega_0} \right] \end{aligned}$$

Q.78 Find the inverse Laplace transform of $X(s) = \frac{s^4 + 3s^3 - 4s^2 + 5s + 5}{s^2 + 3s - 4}$ for all possible ROCs. (8)

Ans: $H(s) = \frac{s^4 + 3s^3 - 4s^2 + 5s + 5}{s^2 + 3s - 4}$
 $= s^2 + \frac{5s + 5}{s^2 + 3s - 4} = s^2 + \frac{5s + 5}{(s + 4)(s - 1)} = s^2 + \frac{3}{s + 4} + \frac{2}{s - 1}$

$$h(t) = \frac{d^2 \delta(t)}{dt^2} + 3e^{-4t}u(t) + 2e^t u(t), \quad \text{ROC } \sigma > 1$$

$$h(t) = \frac{d^2 \delta(t)}{dt^2} + 3e^{-4t}u(t) - 2e^t u(-t), \quad \text{ROC } -4 < \sigma < 1$$

$$h(t) = \frac{d^2 \delta(t)}{dt^2} - 3e^{-4t}u(-t) - 2e^t u(-t), \quad \text{ROC } \sigma < -4$$

Q.79 Using Laplace transform, find the forced and natural responses of the system described by $\frac{d^2 y(t)}{dt^2} + 5\frac{dy(t)}{dt} + 6y(t) = \frac{dx(t)}{dt} + 6x(t)$ when the input is a unit step function and the initial conditions of the system are $y(0^+) = 1$ and $y'(0^+) = 2$. (8)

Ans: Taking the unilateral Laplace transform of both sides of the given eqn, we obtain

$$(s^2 + 5s + 6)Y(s) - sy(0^+) - y'(0^+) - 5y(0^+) = (s + 6)X(s) - x(0^+)$$

Solving for $Y(s)$

$$Y(s) = \frac{(s + 6)X(s) - x(0^+)}{(s + 2)(s + 3)} + \frac{sy(0^+) + y'(0^+) + 5y(0^+)}{(s + 2)(s + 3)}$$

The first term is associated with the forced response of the system, $y_F(t)$. The second term corresponds to the natural response, $y_N(t)$. Substituting for $X(s) = 1/s$, $x(0^+) = 1$, $y(0^+) = 1$, $y'(0^+) = 2$, we obtain

$$Y(s) = \left(\frac{6}{s(s + 2)(s + 3)} \right) + \left(\frac{s + 7}{(s + 2)(s + 3)} \right)$$

$$Y(s) = \left(\frac{1}{s} - \frac{3}{s + 2} + \frac{2}{s + 3} \right) + \left(\frac{5}{s + 2} - \frac{4}{s + 3} \right)$$

$$y(t) = (1 - 3e^{-2t} + 2e^{-3t})u(t) + (5e^{-2t} - 4e^{-3t})u(t)$$

Thus,

$$y_F(t) = (1 - 3e^{-2t} + 2e^{-3t})u(t), \quad y_N(t) = (5e^{-2t} - 4e^{-3t})u(t).$$

Q.80

A casual system is described by $H(z) = \frac{1 + z^{-1}}{(1 - az^{-1})(1 - bz^{-1})}$. For what values of a and b will the system be (i) unstable, (ii) non-causal? **(8)**

Ans: $H(z) = \frac{z(z + 1)}{(z - a)(z - b)}$

The poles are $z = a, b$.

(i) Causal: both a and $b \leq 1$. Stable: both a and $b < 1$.

(ii) Unstable: both or either a or $b \geq 1$. Non-causal: both or either a or $b > 1$.

Q.81

Determine the ROC of $aX(z) + bY(z)$, given that

$$X(z) = \frac{z}{(z - 0.5)(z - 1.5)}, \quad 0.5 < |z| < 1.5, \quad Y(z) = \frac{0.25z}{(z - 0.25)(z - 0.5)}, \quad |z| > 0.5.$$

For what relationship between a and b the ROC will be the largest? **(8)**

Ans: $X(z) = \frac{z}{(z - 0.5)(z - 1.5)}, \quad 0.5 < |z| < 1.5$

$$Y(z) = \frac{0.25z}{(z - 0.25)(z - 0.5)}, \quad |z| > 0.5$$

$$aX(z) + bY(z) = \frac{z(a + 0.25b) \left(z - \frac{0.25a + 0.375b}{a + 0.25b} \right)}{(z - 0.5)(z - 1.5)(z - 0.25)}$$

Since ROC is decided by the three poles, ROC of $aX(z) + bY(z)$ is $0.5 < |z| < 1.5$. However, there is a possibility of cancellation of one of the poles by the created zero. If the pole at 0.5 can be cancelled, then we shall have the ROC given by $0.25 < |z| < 1.5$ the maximum stretch. The condition is

$$\frac{0.25a + 0.375b}{a + 0.25b} = 0.5, \text{ i.e., } a = b.$$

Q.82

Find whether the function $y(t) = x(t) \cdot \cos(100\pi t)$ represent a Linear, Causal, time invariant system. **(8)**

Ans: $y(t) = x(t) \cos 100\pi$

If the inputs are $x_1(t)$ and $x_2(t)$, then the corresponding outputs are

$$y_1(t) = x_1(t) \cos 100\pi$$

$$y_2(t) = x_2(t) \cos 100\pi$$

Now if the input $x_3(t)$ is a linear combination of $x_1(t)$ and $x_2(t)$, i.e.,

$$x_3(t) = ax_1(t) + bx_2(t)$$

where a and b are arbitrary scalars. Then

$$y_3(t) = x_3(t) \cos 100\pi = [ax_1(t) + bx_2(t)] \cos 100\pi$$

$$= ax_1(t) \cos 100\pi + bx_2(t) \cos 100\pi$$

$$= ay_1(t) + by_2(t)$$

Thus, we conclude that the system is linear.

Since the response depends only on the present values, the system is causal.

Since $y(t - \tau) = x(t - \tau) \cos 100\pi(t - \tau) \neq y(t)$, the system is time varying.

Q.83 Find the even and odd parts of the following functions (4)

(i) $f(t) = t \sin t$ (ii) $f(t) = a_0 + a_1 t + a_2 t^2$

Ans:

$$f_o(t) = \frac{1}{2}[f(t) - f(-t)] \quad f_e(t) = \frac{1}{2}[f(t) + f(-t)]$$

(i) $f(t) = t \sin t$

$$f_o(t) = \frac{1}{2}[t \sin t - (-t) \sin(-t)] = 0$$

Here

$$f_e(t) = \frac{1}{2}[t \sin t + (-t) \sin(-t)] = t \sin t$$

(ii) $f(t) = a + a_1 t + a_2 t^2$

Here $f_o(t) = \frac{1}{2}[\{a + a_1 t + a_2 t^2\} - \{a + a_1(-t) + a_2(-t)^2\}] = a_1 t$

$$f_e(t) = \frac{1}{2}[\{a + a_1 t + a_2 t^2\} + \{a + a_1(-t) + a_2(-t)^2\}] = a + a_2 t^2$$

Q.84 Find the average power of the signal $x(t) = (e^{-5t} + 1)u(t)$. (4)

Ans: Average power over an infinite interval

$$\begin{aligned} P_\infty &= \text{Lt}_{T \rightarrow \infty} \frac{1}{2T} \int_{-T}^T |x(t)|^2 dt \\ &= \text{Lt}_{T \rightarrow \infty} \frac{1}{2T} \int_{-T}^T (e^{-10t} + 1 + 2e^{-5t}) u(t) dt = \frac{1}{2T} \int_0^T (e^{-10t} + 1 + 2e^{-5t}) dt \\ &= \frac{1}{2} \text{ W} \end{aligned}$$

Q.85 Find the Fourier Series of the following periodic wave form and hence draw the spectrum. (8)

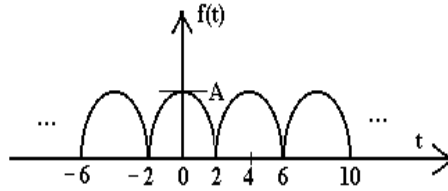

Ans: The function $f(t) = A \cos \frac{\pi}{4}t$, $-2 < t < 2$ has even symmetry.

$$\begin{aligned}
 F_n(t) &= \frac{1}{T} \int_0^T f(t) e^{-jn\omega_0 t} dt \\
 &= \frac{1}{4} \int_{-2}^2 \left(A \cos \frac{\pi}{4}t \right) e^{-jn\frac{\pi}{2}t} dt \\
 &= \frac{A}{4} \int_{-2}^2 \left(\frac{e^{j\frac{\pi}{4}t} + e^{-j\frac{\pi}{4}t}}{2} \right) e^{-jn\frac{\pi}{2}t} dt \\
 &= \frac{A}{8} \left\{ \left[\frac{e^{j\frac{\pi}{4}(1-2n)}}{j\frac{\pi}{4}(1-2n)} \right]_{-2}^2 + \left[\frac{e^{-j\frac{\pi}{4}(1-2n)}}{-j\frac{\pi}{4}(1-2n)} \right]_{-2}^2 \right\} \\
 &= \frac{A}{\pi} \left[\frac{\sin \frac{\pi}{2}(1-2n)}{(1-2n)} + \frac{\sin \frac{\pi}{2}(1+2n)}{(1+2n)} \right]
 \end{aligned}$$

$$\therefore F_0 = \frac{2A}{\pi}, \quad F_1 = \frac{2A}{3\pi}, \quad F_2 = \frac{8A}{15\pi}$$

Q.86 Find the trigonometric Fourier series of the following wave form. (8)

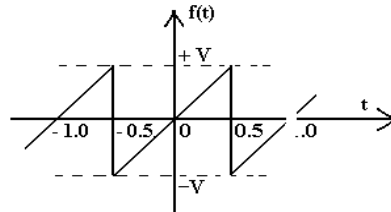

Ans: Here $T = 1$, $\omega_0 = 2\pi$, $f(t) = 2Vt$.

Since the function exhibits an odd symmetry, $a_o = a_n = 0$.

$$b_n = \frac{4}{T} \int_0^{T/2} f(t) \sin n\omega_0 t dt$$

$$\begin{aligned}
 &= 4 \int_0^{0.5} (2Vt) \sin 2\pi t dt \\
 &= 8V \left[\frac{t(-\cos 2\pi t)}{2\pi} \Big|_0^{0.5} - \int_0^{0.5} 1 \cdot \frac{(-\cos 2\pi t)}{2\pi} dt \right] \\
 &= 8V \left[\frac{t(-\cos 2\pi t)}{2\pi} \Big|_0^{0.5} - \frac{(-\sin 2\pi t)}{2\pi \cdot 2\pi} \Big|_0^{0.5} \right] \\
 &= -\frac{2V}{\pi} \cos \pi + 0
 \end{aligned}$$

Now

$$\begin{aligned}
 f(t) &= \sum_1^{\infty} b_n \sin 2\pi t = \frac{2V}{\pi} \sum_1^{\infty} -\cos \pi \cdot \sin 2\pi t \\
 &= \frac{2V}{\pi} \left[\sin 2\pi - \frac{1}{2} \sin 4\pi + \frac{1}{3} \sin 6\pi + \dots \right]
 \end{aligned}$$

Q.87 Define signum and unit step functions? Find the Fourier transforms of these functions. **(8)**

Ans: Signum function

$$\text{Sgm}(t) = \begin{cases} 1, & t > 0 \\ -1, & t < 0 \end{cases}$$

$$\begin{aligned}
 F(\omega) &= \text{Lt}_{a \rightarrow 0} \int_{-\infty}^{\infty} e^{-a|t|} \text{Sgm}(t) e^{-j\omega t} dt \\
 \text{FT [Sgm]} \\
 &= \text{Lt}_{a \rightarrow 0} \left[\int_{-\infty}^0 -e^{-(a+j\omega)t} dt + \int_0^{\infty} e^{-(a+j\omega)t} dt \right] \\
 &= \frac{1}{j\omega} + \frac{1}{j\omega} = \frac{2}{j\omega} \\
 \therefore |F(\omega)| &= \frac{2}{\omega}
 \end{aligned}$$

Unit Step Function

$$u(t) = \begin{cases} 1 & t \geq 0 \\ 0 & t < 0 \end{cases}$$

Since

$$\text{Sgn}(t) = 2u(t) - 1,$$

$$u(t) = \frac{1}{2} [\text{sgn}(t) + 1]$$

$$\therefore \text{FT of } u(t) = \frac{1}{2} \left[\frac{2}{j\omega} + 2\pi\delta(\omega) \right] = \frac{1}{j\omega} + \pi\delta(\omega)$$

Q.88 Determine the Fourier transform a two-sided exponential function $x(t) = e^{-|t|}$ and draw its magnitude spectrum. **(8)**

Ans: $f(t) = e^{-|t|}$

$$\begin{aligned}
 F(\omega) &= \int_{-\infty}^{\infty} e^{-|t|} e^{-j\omega t} dt = \int_{-\infty}^0 e^{(1-j\omega)t} dt + \int_0^{\infty} e^{-(1+j\omega)t} dt \\
 &= \frac{1}{1-j\omega} + \frac{1}{1+j\omega} = \frac{2}{1+\omega^2} \\
 \therefore |F(\omega)| &= \frac{2}{1+\omega^2}
 \end{aligned}$$

Q.89 Find the Discrete Fourier transform of the following sequences.

(i) $x(n) = a^n, 0 < a < 1$ (Find N point DFT)

(ii) $x(n) = \cos n \frac{\pi}{4}$ (Find 4 point DFT) (8)

Ans:

(i)
$$\begin{aligned}
 X(k) &= \sum_{n=0}^{N-1} x(n) e^{-j2\pi k n / N}, \quad k = 0, 1, \dots, N-1 \\
 &= \sum_{n=0}^{N-1} a^n e^{-j2\pi k n / N}, \\
 &= \sum_{n=0}^{N-1} (a e^{-j2\pi k / N})^n = \frac{1 - (a e^{-j2\pi k / N})^N}{1 - a e^{-j2\pi k / N}} \\
 &= \frac{1 - a^N}{1 - a e^{-j2\pi k / N}}, \quad k = 0, 1, \dots, N-1
 \end{aligned}$$

(ii) $N = 4$

$$\begin{aligned}
 x(n) &= \cos 0, \quad \cos \frac{\pi}{4}, \quad \cos \frac{\pi}{2}, \quad \cos \frac{3\pi}{4} \\
 &= 1, \quad 0.707, \quad 0, \quad -0.707
 \end{aligned}$$

$$X(k) = \sum_{n=0}^{N-1} x(n) e^{-j2\pi k n / N}, \quad k = 0, 1, \dots, N-1$$

$$= \sum_{n=0}^3 x(n) e^{-j2\pi k n / N}, \quad k = 0, 1, 2, 3$$

$$\therefore X(k) = \{X(0), \quad X(1), \quad X(2), \quad X(3)\} \\
 = \{1, \quad 1 - j1.414, \quad 1, \quad 1 + j1.414\}$$

Q.90 (i) Find the circular convolution of the following sequence (rectangular)

$$x_1(n) = x_2(n) = \begin{cases} 1, & 0 \leq n \leq N-1 \\ 0, & \text{otherwise} \end{cases}$$

(ii) Compute the DFT of

a) $x(n) = \delta(n)$

b) $x(n) = \delta(n - n_0)$ (4)

Ans: (i)

$$X_1(k) = X_2(k) = \sum_{n=0}^{N-1} W_N^{nk} = \begin{cases} N, & k = 0 \\ 0, & \text{Otherwise} \end{cases}$$

$$X_3(k) = X_1(k)X_2(k) = \begin{cases} N^2, & k = 0 \\ 0, & \text{elsewhere} \end{cases}$$

$$x_3(n) = N, \quad 0 \leq n \leq N-1$$

(ii) a) $X(k) = DFT [\delta(n)] = 1$

b) Since $x[n-n_0] \leftrightarrow e^{-j\omega n_0} X(j\omega)$, we get

$$DFT [\delta(n-n_0)] = e^{-j\omega n_0}$$

Q.91 Find the Nyquist frequency of the following signals.

- (i) $Sa(100t)$ (ii) $Sa^2(100t)$
 (iii) $25 \cos(500\pi t)$ (iv) $10 \text{ sinc}(2t)$ **(8)**

Ans: $Sa \quad x = \frac{\sin x}{x}$

(i) This function will have frequency response a rectangular pulse with

maximum frequency $f_m = \frac{100}{2\pi}$, $f_s = 2f_m = \frac{100}{\pi} \text{ Hz}$

(ii) The $\sin 2(2\pi ft) = (1 - \cos 4\pi ft)/2$, the maximum frequency will be $2f$.

$$f_m = \frac{100}{\pi}, \quad f_s = 2f_m = \frac{200}{\pi} \text{ Hz}$$

(iii) $f_m = \frac{500}{2\pi}, \quad f_s = 2f_m = 500 \text{ Hz}$

(iv) $\text{sinc } t = \frac{\sin \pi t}{\pi}$. Thus $10 \text{ sinc}(2t) = 10 \frac{\sin 2\pi t}{2\pi}$. Its frequency response will be a rectangular pulse $X(f)$ such that the maximum frequency $f_m = 1 \text{ Hz}$. Hence sampling frequency $f_s = 2f_m = 2 \text{ Hz}$.

Q.92 Define ideal low pass filter and show that it is non-causal by finding its impulse response. **(8)**

Ans:

$$H(f) = \begin{cases} e^{-j2\pi f t_0}, & -B \leq f \leq B \\ 0, & |f| > B \end{cases}$$

$$h(t) = -B \int_{-B}^B e^{j2\pi f (t-t_0)} df = \frac{e^{j2\pi f (t-t_0)} \Big|_{-B}^B}{j2\pi f (t-t_0)}$$

$$= \frac{1}{j2\pi (t-t_0)} [e^{j2\pi B (t-t_0)} - e^{-j2\pi B (t-t_0)}]$$

$$= 2B \frac{\sin 2\pi B (t-t_0)}{2\pi B (t-t_0)} = 2B \text{Sinc}[2B(t-t_0)]$$

The system is non-causal as there is some response before $t = 0$.

Q.93 Obtain the Laplace transform of the square wave shown. **(8)**

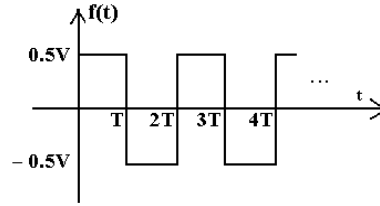

Ans:

$$\begin{aligned}
 \mathcal{L}\{f(t)\} &= \int_0^{2T} f(t)e^{-st} dt + \int_{2T}^{4T} f(t)e^{-st} dt + \dots + \int_{nT}^{(n+2)T} f(t)e^{-st} dt \\
 &= \int_0^{2T} f(t)e^{-st} dt + \left(\int_0^{2T} f(t)e^{-st} dt \right) e^{-2sT} + \dots + \left(\int_0^{2T} f(t)e^{-st} dt \right) e^{-nsT} \\
 &= (1 + e^{-2sT} + e^{-4sT} + \dots + e^{-nsT}) \left[\int_0^{2T} f(t)e^{-st} dt \right] \\
 &= \frac{1}{1 - e^{-2sT}} \left[\int_0^{2T} f(t)e^{-st} dt \right] = \frac{1}{1 - e^{-2sT}} \left[\int_0^T 0.5e^{-st} dt + \int_T^{2T} 0.5e^{-st} dt \right] \\
 &= \frac{1}{1 - e^{-2sT}} \left[-\frac{0.5}{s} (e^{-sT} - 1) + \frac{0.5}{s} (e^{-2sT} - e^{-sT}) \right] \\
 &= \frac{1}{1 - e^{-2sT}} \left[\frac{0.5}{s} (1 - e^{-sT})^2 \right] \\
 &= \frac{0.5}{s} \left[\frac{1 - e^{-sT}}{1 + e^{-sT}} \right]
 \end{aligned}$$

Q.94 Find the inverse Laplace transforms of the following functions.

(i) $\frac{s^2}{(s+a)^2 + b^2}$ (ii) $\ln\left(\frac{s+1}{s+2}\right)$ **(8)**

Ans:

$$\begin{aligned}
 \text{(i)} \quad \mathcal{L}^{-1} \frac{s^2}{(s+a)^2 + b^2} &= s \left[\frac{s+a}{(s+a)^2 + b^2} - \frac{a}{b} \frac{b}{(s+a)^2 + b^2} \right] \\
 &= \frac{d}{dt} f(t) + f(0^+) \quad \text{where} \quad f(t) = \left[e^{-at} \cos bt - \frac{a}{b} e^{-at} \sin bt \right] u(t) \\
 &= \left[(-be^{-at} \sin bt - ae^{-at} \cos bt) + \left(-ae^{-at} \cos bt + \frac{a^2}{b} e^{-at} \sin bt \right) + \delta(t) \right] u(t) \\
 &= \left(\frac{a^2}{b} \sin bt - 2a \cos bt - b \sin bt \right) e^{-at} u(t) + \delta(t) \\
 \text{(ii)} \quad F(s) &= \ln \frac{s+1}{s+2} = \ln(s+1) - \ln(s+2)
 \end{aligned}$$

$$\begin{aligned} \therefore \frac{dF}{ds} &= \frac{1}{s+1} - \frac{1}{s+2} \\ \therefore \left[\frac{dF}{ds} \right] &= (e^{-t} - e^{-2t})u(t) \end{aligned}$$

Hence,

$$\begin{aligned} \mathcal{L}^{-1}[F(s)] &= -\frac{1}{t} \mathcal{L}^{-1} \left[\frac{dF}{ds} \right] \\ &= -\frac{1}{t} [e^{-t} - e^{-2t}]u(t) \end{aligned}$$

Q.95 Obtain the z transforms and hence the regions of convergence of the following sequences.

(i) $x(n) = [u(n) - u(n-10)]2^{-n}$ (ii) $x(n) = \cos(\pi n)u(n)$ **(8)**

Ans: (i) $x(n) = [u(n) - u(n-10)]2^{-n}$

$$Z[x(n)] = \sum_{n=0}^9 2^{-n} Z^{-n}$$

$$= \sum_{n=0}^9 \left(\frac{1}{2z} \right)^n = \frac{1 - \left(\frac{1}{2z} \right)^{10}}{1 - \frac{1}{2z}}, \quad \text{ROC is } |z| > \frac{1}{2}$$

(ii) $x(n) = \cos(\pi n)u(n) = \frac{e^{j\pi n} + e^{-j\pi n}}{2} u(n)$

$$\begin{aligned} \therefore Z[x(n)] &= \frac{1}{2} \left[\sum_{n=0}^9 e^{j\pi n} z^{-n} + \sum_{n=0}^9 e^{-j\pi n} z^{-n} \right] = \frac{1}{2} \left[\sum_{n=0}^{\infty} (e^{j\pi} z^{-1})^n + \sum_{n=0}^{\infty} (e^{-j\pi} z^{-1})^n \right] \\ &= \frac{1}{2} \left[\frac{1}{1 - e^{j\pi} z^{-1}} + \frac{1}{1 - e^{-j\pi} z^{-1}} \right] \\ &= \frac{1}{2} \left[\frac{1}{1 + z^{-1}} + \frac{1}{1 + z^{-1}} \right] = \frac{z}{z+1}, \quad \text{ROC is } |z| > 1 \end{aligned}$$

Q.96 A second order discrete time system is characterized by the difference equation $y(n) - 0.1y(n-1) - 0.02y(n-2) = 2x(n) - x(n-1)$. Find $y(n)$ for $n \geq 0$ when $x(n) = u(n)$ and the initial conditions are given as $y(-1) = -10$, $y(-2) = 20$ **(8)**

Ans:

Since $y(n) - 0.1y(n-1) - 0.02y(n-2) = 2x(n) - x(n-1)$,

$$\begin{aligned} Y(z) - 0.1[Y(-1) + z^{-1}Y(z)] - 0.02[Y(-2) + z^{-1}Y(-1) + z^{-2}Y(z)] \\ = 2X(z) - z^{-1}X(z) \end{aligned}$$

Substituting the initial values and rearranging, we get

$$Y(z)[1 - 0.1z^{-1} - 0.02z^{-2}] + 1 - 0.4 + 0.2z^{-1} = \frac{2z}{z-1} - \frac{1}{z-1}$$

$$Y(z) = \frac{(z-0.2)(z-0.1)}{z^2} = \frac{2z-1}{z-1} - \frac{0.2}{z} - 0.6$$

$$Y(z) = \frac{(2z-1)z^2}{(z-1)(z-0.2)(z-0.1)} - \frac{0.2}{z(z-0.2)(z-0.1)} - \frac{0.6}{(z-0.2)(z-0.1)}$$

$$= Y_1(z) + Y_2(z) + Y_3(z)$$

Now

$$\frac{Y_1(z)}{z} = \frac{(2z-1)z}{(z-1)(z-0.2)(z+0.1)}$$

By partial fraction expansion, we get

$$Y_1(z) = \frac{1.13z}{(z-1)} + \frac{0.5z}{(z-0.2)} + \frac{0.36z}{(z+0.1)}$$

Similarly

$$Y_2(z) = \frac{2}{3} \frac{z}{(z-0.2)} + -\frac{2}{3} \frac{z}{(z+0.1)}$$

$$Y_3(z) = 0.4 \frac{z}{(z-0.2)} + 0.2 \frac{z}{(z+0.1)}$$

Thus,

$$Y(z) = \frac{1.13z}{(z-1)} - \frac{0.56z}{(z-0.2)} + \frac{0.83z}{(z+0.1)}$$

Hence

$$y(n) = [1.13 - 0.56(0.2)^n + 0.83(0.1)^n] \mu(n)$$

Q.97

A continuous random variable has a pdf $f(x) = Kx^2e^{-x}; x \geq 0$. Find K , and mean and variance of the random variable. **(8)**

Ans:

By the property of PDF

$$\int_0^{\infty} Kx^2e^{-x} dx = 1$$

Or, $2K = 1 \rightarrow K = 1/2$

Mean value of x is

$$E(x) = \int_{R_x} xf(x)dx = \int_0^{\infty} xKx^2e^{-x} dx = 0.5 \int_0^{\infty} x^3e^{-x} dx = 3$$

Now

$$E(x^2) = \int_{R_x} x^2 f(x)dx = \int_0^{\infty} x^2 Kx^2e^{-x} dx = 0.5 \int_0^{\infty} x^4e^{-x} dx = 12$$

Variance of x is

$$V(x) = E(x^2) - \{E(x)\}^2 = 12 - 9 = 3.$$

Q.98

Find the autocorrelation of the following functions:

(i) $g(t) = e^{-at}u(t)$

(ii) $g(t) = A\Pi\left(\frac{t}{T}\right)$ where $A\Pi\left(\frac{t}{T}\right)$ is a rectangular pulse with period T and

magnitude A . (8)

Ans:

(i) $g(t) = e^{-at}u(t)$

$$R_g(\tau) = \int_{-\infty}^{\infty} g(t)g(t-\tau)dt$$

$$\int_{-\infty}^{\infty} e^{-at}e^{-a(t-\tau)}u(t)dt = e^{a\tau} \int_0^{\infty} e^{-2at}dt = \frac{e^{-a\tau}}{2a}$$

(ii) $g(t) = A\Pi\left(\frac{t}{T}\right)$

$$R_g(\tau) = \int_{-\infty}^{\infty} g(t)g(t-\tau)dt = R_g(-\tau)$$

For $|\tau| < T$

$$R_g(\tau) = \int_{\tau}^T A^2 dt = A^2(T - \tau)$$

For $|\tau| \geq T$

$$R_g(\tau) = \int_T^{\infty} g(t)g(t-\tau)dt = 0, |\tau| \geq T$$

$$= \begin{cases} A^2(T - \tau), & |\tau| < T \\ 0 & |\tau| \geq T. \end{cases}$$

Q.99 Find the Fourier series of the following periodic impulse train. (8)

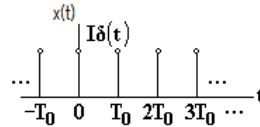

Ans:

$$A_0 = \frac{1}{T_0} \int_{-T_0/2}^{T_0/2} \delta(t)dt = \frac{I}{T_0}$$

$$A_n = \frac{2I}{T_0} \int_{-T_0/2}^{T_0/2} \delta(t) \cos \frac{2\pi nt}{T_0} dt = \frac{2I}{T_0}$$

$$B_n = \frac{2I}{T_0} \int_{-T_0/2}^{T_0/2} \delta(t) \sin \frac{2\pi nt}{T_0} dt = 0$$

$$\therefore x(t) = \frac{I}{T_0} + \frac{2I}{T_0} \sum_{n=1}^{\infty} \cos \frac{2\pi nt}{T_0} = \frac{I}{T_0} \sum_{n=-\infty}^{\infty} e^{\frac{2\pi nt}{T_0}}$$

Q.100 The Magnitude and phase of the Fourier Transform of a signal $x(t)$ are shown in the following figure. Find the signal $x(t)$.

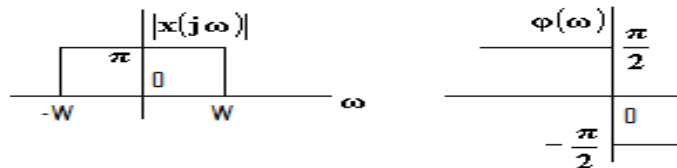

Ans:

$$X(j\omega) = \pi, \quad -W \leq \omega \leq W$$

and

$$\phi(j\omega) = \angle X(j\omega) = \begin{cases} \pi/2, & \omega < 0 \\ -\pi/2, & \omega > 0 \end{cases}$$

Thus

$$X(j\omega) = \begin{cases} \pi e^{j\pi/2}, & -W \leq \omega \leq 0 \\ \pi e^{-j\pi/2}, & 0 \leq \omega \leq W \end{cases}$$

$$\begin{aligned} x(t) &= F^{-1}[X(j\omega)] = \frac{1}{2\pi} \int_{-\infty}^{\infty} X(j\omega) e^{j\omega t} d\omega \\ &= \frac{1}{2\pi} \left[\int_{-W}^0 \pi e^{j\pi/2} e^{j\omega t} d\omega + \int_0^W \pi e^{-j\pi/2} e^{j\omega t} d\omega \right] \\ &= \frac{1}{2} \left[\int_0^W e^{j(\pi/2 - \omega t)} d\omega + \int_0^W e^{-j(\pi/2 - \omega t)} d\omega \right] \\ &= \frac{1}{2} \left[\int_0^W \left(e^{j(\pi/2 - \omega t)} + e^{-j(\pi/2 - \omega t)} \right) d\omega \right] = \int_0^W \cos(\pi/2 - \omega t) d\omega = \int_0^W (\sin \omega t) d\omega \\ &= \frac{1}{t} [1 - \cos Wt] = \frac{1}{t} 2 \sin^2 \left(\frac{Wt}{2} \right) = \frac{W^2 t}{2\pi^2} \operatorname{sinc}^2 \left(\frac{Wt}{2\pi} \right) \end{aligned}$$

Q.101 Find the Discrete Time Fourier Transforms of the following signals and draw its spectra. (8)

(i) $x_1(n) = a^{|n|} \quad |a| < 1$

(ii) $x_2(n) = \cos \omega_0 n$ where $\omega_0 = \frac{2\pi}{5}$.

Ans:

(i) $x(n) = a^{|n|}, |a| < 1$

$$\begin{aligned} X(e^{j\omega}) &= \sum_{n=-\infty}^{\infty} a^{|n|} e^{j\omega n} = \sum_{n=-\infty}^{-1} a^{-n} e^{j\omega n} + \sum_{n=0}^{\infty} a^n e^{j\omega n} = \sum_{n=1}^{\infty} (ae^{-j\omega})^n + \sum_{n=0}^{\infty} (ae^{j\omega})^n \\ &= \frac{ae^{-j\omega}}{1 - ae^{-j\omega}} + \frac{1}{1 - ae^{j\omega}} = \frac{1 - a^2}{1 - 2a \cos \omega + a^2} \end{aligned}$$

(ii) $x(n) = \cos \omega_0 n = \frac{1}{2} [e^{j\omega_0 n} + e^{-j\omega_0 n}]$

$$\begin{aligned} X(e^{j\omega}) &= \sum_{l=-\infty}^{\infty} \pi \delta \left[\omega - \frac{2\pi}{5} - 2\pi l \right] + \sum_{l=-\infty}^{\infty} \pi \delta \left[\omega + \frac{2\pi}{5} - 2\pi l \right] \\ &= \pi \delta \left[\omega - \frac{2\pi}{5} \right] + \pi \delta \left[\omega + \frac{2\pi}{5} \right], \quad -\pi \leq \omega < \pi \end{aligned}$$

Q.102 The frequency response for a causal and stable continuous time LTI system is expressed as $H(j\omega) = \frac{1 - j\omega}{1 + j\omega}$. (8)

(i) Determine the magnitude of $H(j\omega)$

(ii) Find phase response of $H(j\omega)$

(iii) Find Group delay.

Ans:

- (i) $[H(\omega)] = \left| \frac{1 - j\omega}{1 + j\omega} \right| = \frac{\sqrt{1 + \omega^2}}{\sqrt{1 + \omega^2}} = 1$
- (ii) $\angle H(j\omega) = \tan^{-1}(-\omega) - \tan^{-1}(\omega) = -2 \tan^{-1}(\omega)$
- (iii) Group delay $= -\frac{d}{d\omega} \angle H(j\omega) = -\frac{d}{d\omega} (-2 \tan^{-1} \omega) = \frac{2}{1 + \omega^2}$

Q.103 Find the Nyquist rate and Nyquist interval for the continuous-time signal

$$x(t) = \frac{1}{2\pi} \cos(4000\pi t) \cdot \cos(1000\pi t). \quad (4)$$

Ans:

$$x(t) = \frac{1}{2\pi} \cos 4000\pi t \cdot \cos 1000\pi t = \frac{1}{4\pi} [\cos 5000\pi t + \cos 3000\pi t]$$

The highest frequency present is $\omega_h = 5000\pi$, i.e., $f_h = 2.5$ kHz. Nyquist rate is 5 kHz and Nyquist interval = $1/5$ k = 0.2 msec.

Q.104 Consider a discrete-time LTI system with impulse response $h(n)$ given by

$$h(n) = \alpha^n u(n).$$

Determine whether the system is causal, and the condition for stability. (4)

Ans:

Since $h(n) = 0$ for $n < 0$, the system is causal.

Now

$$\sum_{k=-\infty}^{\infty} |h(k)| = \sum_{k=-\infty}^{\infty} |\alpha^k u(k)| = \sum_{k=0}^{\infty} |\alpha|^k = \frac{1}{1 - |\alpha|}, |\alpha| < 1.$$

Thus the system is stable if $|\alpha| < 1$.

Q.105 Check for Causality, Linearity of the following signals. (8)

- (i) $y(t) = x(\sqrt{t})$
- (ii) $y(t) = x(t^2)$
- (iii) $y(t) = 10x(t+2) + 5$
- (iv) $y[n] = \sum_{k=-\infty}^n x[k]$

Ans:

(i) Non-causal: $y(0.01) = x(0.1)$, i.e., y depends upon the future value of x .

linear: it is of the form $y = mx$.

(ii) Non-causal: $y(2) = x(4)$, i.e., y depends upon the future value of x . linear:

it is of the form $y = mx$.

(iii) Non-causal: $y(t)$ depends upon $x(t+2)$ the future value of $x(t)$. Non-linear:

it is of the form $y = mx + c$.

(iv) Non-causal: It has the value for $n < 0$. Linear : it is of the form $y = mx$.

Q.106 Determine the Laplace transform of the following functions. (6)

- (i) $x(t) = \cos^3(3t)$
- (ii) $x(t) = t \sin at$

Ans:

(i)

$$x(t) = \cos^3 t = \frac{1}{4} [\cos 9t + 3 \cos 3t]$$

$$\therefore x(t) = \frac{1}{4} \left[\frac{s}{s^2 + 9^2} + \frac{3s}{s^2 + 3^2} \right] = \frac{1}{4} \left[\frac{s}{s^2 + 81} + \frac{3s}{s^2 + 9} \right].$$

(ii) $x(t) = t \sin at$

$$\therefore \mathcal{L} x(t) = -\frac{d}{ds} \mathcal{L}(\sin at) = -\frac{d}{ds} \left(\frac{a}{s^2 + a^2} \right) = \frac{2as}{(s^2 + a^2)^2}.$$

Q.107 The transfer function of the system is given by $H(s) = \frac{2}{s+3} + \frac{1}{s-2}$. Determine the impulse responses if the system is (i) stable (ii) causal. State whether the system will be stable and causal simultaneously. **(10)**

Ans: There are following three possible impulse responses.

$$h_1(t) = 2e^{-3t}u(t) + e^{2t}u(t), \sigma > 2$$

$$h_2(t) = 2e^{-3t}u(t) - e^{2t}u(-t), -3 < \sigma < 2$$

$$h_3(t) = -2e^{-3t}u(-t) - e^{2t}u(-t), \sigma < -3$$

$h_1(t)$ is causal but unstable due to the pole at $s = 2$, $h_2(t)$ is non-causal due to the pole at $s = 2$ but stable, and $h_3(t)$ is also non-causal due to both the poles but stable. Thus, the system cannot be both causal and stable simultaneously.

Q.108 Determine the inverse Z transform of the following $X(z)$ by the partial fraction expansion method. **(8)**

$$X(z) = \frac{z+2}{2z^2 - 7z + 3}$$

if the ROCs are (i) $|z| > 3$, (ii) $z < \frac{1}{2}$, (iii) $\frac{1}{2} < |z| < 3$

Ans: $X(z) = \frac{z+2}{2z^2 - 7z + 3}$

$$\frac{X(z)}{z} = \frac{z+2}{2z(z^2 - 7z + 3)} = \frac{z+2}{2z(z-0.5)(z-3)} = \frac{2/3}{z} - \frac{1}{z-0.5} + \frac{1/3}{z-3}$$

Or $X(z) = \frac{2}{3} - \frac{z}{z-0.5} + \frac{(1/3)z}{z-3}$, poles are $p_1 = 0.5, p_2 = 3$

(i) When $|z| > 3$ all poles are interior, $x(n)$ is causal.

Therefore,
$$x(n) = \frac{2}{3} \delta(n) - \left(\frac{1}{2}\right)^n u(n) + \frac{1}{3} (3)^n u(n)$$

(ii) When $|z| < \frac{1}{2}$, all poles are exterior, $x(n)$ is non-causal.

$$\therefore x(n) = \frac{2}{3} \delta(n) + \left(\frac{1}{2}\right)^n u(-n-1) - \frac{1}{3} (3)^n u(-n-1)$$

(iii) When $\frac{1}{2} < |z| < 3$, p_1 is interior and p_2 is exterior.

$$\therefore x(n) = \frac{2}{3} \delta(n) - \left(\frac{1}{2}\right)^n u(n) - \frac{1}{3} (3)^n u(-n-1)$$

Q.109 A Causal discrete-time LTI system is described by

$$y(n) - \frac{3}{4}y(n-1) + \frac{1}{8}y(n-2) = x(n)$$

where $x(n)$ and $y(n)$ are the input and output of the system, respectively.

- (i) Determine the $H(z)$ for causal system function
- (ii) Find the impulse response $h(n)$ of the system
- (iii) Find the step response of the system (8)

Ans:

i)
$$Y(z) - \frac{3}{4}z^{-1}Y(z) + \frac{1}{8}z^{-2}Y(z) = X(z)$$

$$\therefore H(z) = \frac{Y(z)}{X(z)} = \frac{1}{1 - \frac{3}{4}z^{-1} + \frac{1}{8}z^{-2}} = \frac{z^2}{\left(z - \frac{1}{2}\right)\left(z - \frac{1}{4}\right)}, |z| > \frac{1}{2}.$$

(ii)
$$\frac{H(z)}{z} = \frac{z}{\left(z - \frac{1}{2}\right)\left(z - \frac{1}{4}\right)} = \frac{2}{z - \frac{1}{2}} - \frac{1}{z - \frac{1}{4}}$$

$$\therefore h(n) = \left[2\left(\frac{1}{2}\right)^n - \left(\frac{1}{4}\right)^n \right] u(n)$$

(iii) Here
$$X(z) = \frac{z}{z-1}, |z| > 1$$

$$Y(z) = X(z)H(z) = \frac{z^3}{(z-1)\left(z - \frac{1}{2}\right)\left(z - \frac{1}{4}\right)}, |z| > 1$$

$$= \frac{8}{3} \frac{z}{z-1} - 2 \frac{z}{z - \frac{1}{2}} + \frac{1}{3} \frac{z}{z - \frac{1}{4}}, |z| > 1$$

$$y(n) = \left[\frac{8}{3} - 2\left(\frac{1}{2}\right)^n + \frac{1}{3}\left(\frac{1}{4}\right)^n \right] u(n)$$

Q.110 A random variable X has the uniform distribution given by

$$f_x(x) = \begin{cases} \frac{1}{2\pi}, & \text{for } 0 \leq x \leq 2\pi \\ 0, & \text{otherwise} \end{cases}$$

Determine mean, mean square, Variance. (10)

Ans: Mean $m_x = \int_{-\infty}^{\infty} xf_x(x)dx = \int_0^{2\pi} x \frac{1}{2\pi} dx = \pi$

Mean square $\overline{X^2} = E(X^2) = \int_{-\infty}^{\infty} x^2 f_x(x)dx = \frac{1}{2\pi} \int_0^{2\pi} x^2 dx = \frac{4}{3}\pi^2$

Variance: $\sigma_x^2 = E(X^2) - m_x^2 = \frac{4}{3}\pi^2 - \pi^2 = \frac{1}{3}\pi^2$

$$\sigma_x = \frac{\pi}{\sqrt{3}}$$

Q.111 Discuss the properties of Gaussian PDF. (6)

Ans:

Property 1: The peak value occurs at $x = m$, i.e., mean value

$$f_x(x) = \frac{1}{\sigma\sqrt{2\pi}} \text{ at } x = m \text{ (mean)}$$

Property 2: Plot of Gaussian PDF exhibits even symmetry around mean value, i.e.,

$$f_x(m - \sigma) = f_x(m + \sigma)$$

Property 3: The mean under PDF is $1/\sqrt{2}$ for all values of x below mean value and $1/2$ for all values of x above mean value, i.e.,

$$P(X \leq m) = P(X > m) = \frac{1}{2}$$

Q.112 A stationary random variable $x(t)$ has the following autocorrelation function

$R_x(\tau) = \sigma^2 e^{-\mu|\tau|}$ where σ^2, μ are constants. $R_x(t)$ is passed through a filter whose impulse response is $h(\tau) = \alpha e^{-\alpha\tau} u(\tau)$ where α is a constant, $u(\tau)$ is unit step function.

(i) Find power spectral density of random signal $x(t)$.

(ii) Find power spectral density of output signal $y(t)$. (8)

Ans: (i)

$$S_X(\omega) = \text{FT}[R_X(t)] = \int_{-\infty}^{\infty} R_X(\tau) e^{-j\omega\tau} d\tau$$

$$= \int_{-\infty}^{\infty} \sigma^2 e^{-\mu|\tau|} e^{-j\omega\tau} d\tau = \frac{2\mu\sigma^2}{\mu^2 + \omega^2}$$

(ii)

$$H(\omega) = \text{FT}[h(\tau)] = \int_{-\infty}^{\infty} \alpha e^{-\alpha\tau} u(\tau) e^{-j\omega\tau} d\tau = \frac{\alpha}{\alpha + j\omega}$$

$$S_Y(\omega) = |H(\omega)|^2 S_X(\omega) = \left| \frac{\alpha}{\alpha + j\omega} \right|^2 S_X(\omega) = \frac{\alpha}{\alpha^2 + \omega^2} \frac{2\mu\sigma^2}{\mu^2 + \omega^2}$$

Q.113 Determine the convolution of the following two continuous time functions.

$$x(t) = e^{-at} u(t), \quad a > 0 \quad \text{and} \quad h(t) = u(t) \quad (8)$$

Ans:

$$y(t) = h(t) * u(t) = \int_{-\infty}^{\infty} x(\lambda) h(t - \lambda) d\lambda = \int_{-\infty}^{\infty} e^{-a\lambda} u(\lambda) u(t - \lambda) d\lambda = \int_0^t e^{-a\lambda} d\lambda$$

$$= -\frac{1}{a} [e^{-a\lambda}]_0^t = \frac{1}{a} [1 - e^{-at}]$$

Q.114 Determine signal energy and power of the following signals

$$(i) x(n) = u(n) \quad (ii) x(t) = e^{-3t} \quad (8)$$

Ans:

$$(i) \quad E = \sum_{n=-\infty}^{\infty} x^2[n] = \sum_{n=-\infty}^{\infty} u^2[n] = 1$$

$$P = \lim_{N \rightarrow \infty} \frac{1}{2N} \sum_{n=-N}^N x^2[n] = \lim_{N \rightarrow \infty} \frac{1}{2N} \sum_{n=-N}^N u^2[n] = 1.$$

$$(ii) \quad E = \int_{-T}^T [e^{-3t}]^2 dt = \int_{-T}^T [e^{-6t}] dt = -\frac{1}{6} [e^{-6T} - e^{6T}] = \infty$$

$$P = \lim_{T \rightarrow \infty} \frac{1}{2T} E = \lim_{T \rightarrow \infty} -\frac{1}{12T} [e^{-6T} - e^{6T}] = \infty$$

Q.115 Find the DTFT of the sequence $x(n) = u(n)$. (4)

Ans:

$$\text{DTFT } x(n) = X(e^{j\omega}) = \sum_{n=-\infty}^{\infty} x(n)e^{-j\omega n} = \sum_{n=0}^{\infty} 1 \cdot e^{-j\omega n} = \frac{1}{1 - e^{-j\omega}}$$

It is not convergent for $\omega = 0$.

$$\therefore X(e^{j\omega}) = \frac{e^{j\omega/2}}{2 \sin \frac{\omega}{2}}, \omega \neq 0.$$

Q.116 Find the inverse Fourier transform of $\delta(\omega)$. (4)

Ans:

$$F^{-1}[\delta(\omega)] = \frac{1}{2\pi} \int_{-\infty}^{\infty} \delta(\omega) e^{j\omega t} d\omega = \frac{1}{2\pi} [e^{j\omega t}]_{\omega=0} = \frac{1}{2\pi}$$

Q.117 Check whether the following signals are energy or power signal and hence find the corresponding energy or power. (6)

(i) $x(t) = Ae^{-\alpha t} \cdot u(t), \alpha > 0$

(ii) $x(t) = \cos^2 \omega_0 t$

Ans:

(i) $x(t) = Ae^{-\alpha t} u(t), \alpha > 0$

Then
$$E = \int_{-\infty}^{\infty} |x(t)|^2 dt = A^2 \left. \frac{e^{-2\alpha t}}{-2\alpha} \right|_0^{\infty} = \frac{A^2}{2\alpha}$$

Since $0 < E < \infty$, $x(t)$ is an energy signal.

(ii) Since $x(t) = \cos^2 \omega_0 t$ is a periodic function, it is a power signal.

$$P = \lim_{T_o \rightarrow \infty} \frac{1}{T_o} \int_{-T_o/2}^{T_o/2} x^2(t) dt$$

$$= \lim_{T_o \rightarrow \infty} \frac{1}{T_o} \int_{-T_o/2}^{T_o/2} [\cos^2 \omega_0 t]^2 dt = \lim_{T_o \rightarrow \infty} \frac{1}{T_o} \int_{-T_o/2}^{T_o/2} [\cos^4 \omega_0 t] dt$$

$$= \lim_{T_o \rightarrow \infty} \frac{1}{T_o} \int_{-T_o/2}^{T_o/2} \frac{1}{8} [3 + 4 \cos 2\omega_0 t + \cos \omega_0 t] dt = \frac{3}{8}$$

Q.118 Find the convolution of two rectangular pulse signals shown below. **(10)**

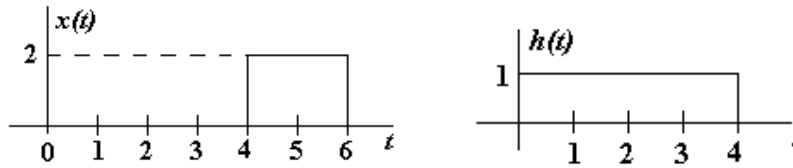

Ans:

For $-\infty \leq t \leq 4$ and $t \geq 10$ the output is 0.

For $4 \leq t \leq 6$, $y(t) = \int_4^t 2 dt = 2(t - 4)$

For $6 < t \leq 8$, $y(t) = \int_6^8 2 dt = 2(8 - 6) = 4$

For $8 < t \leq 10$, $y(t) = \int_t^{10} 2 dt = 2(10 - t)$

Thus $y(t)$ is as shown in the figure.

Q 119 Given the Gaussian pulse $x(t) = e^{-\pi t^2}$, determine its Fourier transform. **(8)**

Ans:

$$X(\omega) = \int_{-\infty}^{\infty} x(t)e^{-j\omega t} dt = \int_{-\infty}^{\infty} e^{-\pi t^2} e^{-j\omega t} dt = \int_{-\infty}^{\infty} e^{-(\pi t^2 + j\omega t)} dt$$

Expressing $\pi t^2 + j\omega t = \left(\sqrt{\pi}t + \frac{j\omega}{2\sqrt{\pi}}\right)^2 + \frac{\omega^2}{4\pi}$,

we have

$$X(\omega) = \int_{-\infty}^{\infty} e^{-\left(\sqrt{\pi}t + \frac{j\omega}{2\sqrt{\pi}}\right)^2} e^{-\frac{\omega^2}{4\pi}} dt = e^{-\frac{\omega^2}{4\pi}} \int_{-\infty}^{\infty} e^{-\left(\sqrt{\pi}t + \frac{j\omega}{2\sqrt{\pi}}\right)^2} dt$$

Let $u = \sqrt{\pi}t + \frac{j\omega}{2\sqrt{\pi}}$,

Then $X(\omega) = e^{-\frac{\omega^2}{4\pi}} \frac{2}{\sqrt{\pi}} \int_0^{\infty} e^{-u^2} du = e^{-\frac{\omega^2}{4\pi}} \frac{2}{\sqrt{\pi}} \frac{\sqrt{\pi}}{2} = e^{-\frac{\omega^2}{4\pi}}$

Q.120 Find the exponential Fourier series of the following signal. **(8)**

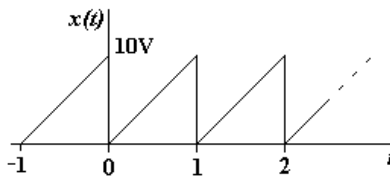

Ans:

Here $T = 1\text{sec}, \omega_o = 2\pi,$

$$x(t) = \frac{10}{T}t = 10t$$

$$C_n = \frac{1}{T} \int_0^T x(t)e^{-jn\omega_o t} dt = \int_0^1 10te^{-j2\pi n t} dt$$

$$= 10 \left[\frac{te^{-j2\pi n t}}{-j2\pi n} \Big|_0^1 - \int_0^1 \frac{e^{-j2\pi n t}}{-j2\pi n} dt \right]$$

$$= 10 \left[\frac{e^{-j2\pi n}}{-j2\pi n} + \frac{e^{-j2\pi n}}{4\pi^2 n^2} \Big|_0^1 \right]$$

$$= j \frac{5}{\pi n}$$

Now

$$x(t) = \sum_{n=-\infty}^{\infty} C_n e^{-j2\pi n t} = \sum_{n=-\infty}^{\infty} j \frac{5}{\pi n} e^{j2\pi n t};$$

$$\theta_n = \tan^{-1} \infty = \begin{cases} \frac{\pi}{2} & n \geq 0 \\ -\frac{\pi}{2} & n \leq 0 \end{cases}$$

Q.121 State and prove the following properties of DTFT. (6)

- (i) Time shifting, frequency shifting
- (ii) Conjugate symmetry
- (iii) Time reversal.

Ans:

$$x(n) \leftrightarrow X(e^{j\omega})$$

(i) Time shifting: $x(n - n_o) \leftrightarrow e^{-j\omega n_o} X(e^{j\omega})$

Frequency shifting: $e^{j\omega_o n} x(n) \leftrightarrow X(e^{j(\omega - \omega_o)})$

(ii) $x^*(n) \leftrightarrow X^*(e^{-j\omega})$

$$X(e^{j\omega}) = X^*(e^{-j\omega}), \quad x(n) \text{ real}$$

$$\text{Even } [x(n)] \leftrightarrow \text{Re} [X(e^{j\omega})]$$

$$\text{Odd } [x(n)] \leftrightarrow j \text{Im} [X(e^{j\omega})]$$

(iii) $x(-n) \leftrightarrow X(e^{-j\omega})$

Q.122 Consider a stable causal LTI system whose input $x(n]$ and output $y(n]$ are related through second order difference equation

$$y(n) - \left(\frac{3}{4}\right)y(n-1) + \frac{1}{8}y(n-2) = 2x(n).$$

Determine the response for the given input $x(n) = \left(\frac{1}{4}\right)^n u(n)$ (10)

Ans:

$$y(n) - \frac{3}{4}y(n-1) + \frac{1}{8}y(n-2) = 2x(n) = 2\left(\frac{1}{4}\right)^n u(n)$$

Taking DTFT on both sides

$$Y(e^{j\omega}) - \frac{3}{4}e^{-j\omega}Y(e^{j\omega}) + \frac{1}{8}e^{-2j\omega}Y(e^{j\omega}) = \frac{2}{1 - \frac{1}{4}e^{-j\omega}}$$

$$\begin{aligned} Y(e^{j\omega}) &= \frac{2}{\left[1 - \frac{3}{4}e^{-j\omega} + \frac{1}{8}e^{-2j\omega}\right] \left[1 - \frac{1}{4}e^{-j\omega}\right]} \\ &= \frac{2}{\left[1 - \frac{1}{2}e^{-j\omega}\right] \left[1 - \frac{1}{4}e^{-j\omega}\right] \left[1 - \frac{1}{4}e^{-j\omega}\right]} \\ &= \frac{2}{\left[1 - \frac{1}{2}e^{-j\omega}\right] \left[1 - \frac{1}{4}e^{-j\omega}\right]^2} \\ &= \frac{8}{\left[1 - \frac{1}{2}e^{-j\omega}\right]} - \frac{4}{\left[1 - \frac{1}{4}e^{-j\omega}\right]} - \frac{2}{\left[1 - \frac{1}{4}e^{-j\omega}\right]^2} \end{aligned}$$

Taking inverse DFT

$$y(n) = 8\left(\frac{1}{2}\right)^n u(n) - 4\left(\frac{1}{4}\right)^n u(n) - 2(n+1)\left(\frac{1}{4}\right)^n u(n)$$

Q.123 A continuous time signal is $x(t) = 8 \cos 200\pi t$ (8)

- (i) Determine the minimum sampling rate.
- (ii) If $f_s = 400$ Hz, what is discrete time signal obtained after sampling?
- (iii) If $f_s = 150$ Hz, what is discrete time signal obtained after sampling?

Ans: Here $\omega = 200\pi \rightarrow f = 100$ Hz

(i) Minimum sampling rate = $2f = 2 \times 100 = 200$ Hz

$$(ii) \quad \frac{f}{f_s} = \frac{100}{400} = \frac{1}{4}$$

$$\therefore x(n) = 8 \cos 2\pi f n = 8 \cos 2\pi \frac{1}{4} n = 8 \cos \frac{\pi n}{2}$$

$$(iii) \text{ Here } \quad \frac{f}{f_s} = \frac{100}{150} = \frac{2}{3}$$

$$\therefore x(n) = 8 \cos 2\pi f n = 8 \cos 2\pi \frac{2}{3} n = 8 \cos \frac{4\pi n}{3} = 8 \cos \left(2\pi - \frac{2\pi}{3}\right) n = 8 \cos \frac{4\pi n}{3}$$

Q.124 State and prove Parseval's theorem for continuous time periodic signal. (8)

Ans:

Parseval's theorem: The Parseval's theorem states that the energy in the time-domain representation of a signal is equal to the energy in the frequency domain representation normalized by 2π .

Proof:

The energy in a continuous time non-periodic signal is

$$E = \int_{-\infty}^{\infty} |x(t)|^2 dt.$$

Since $|x(t)|^2 = x(t)x^*(t)$, from the Fourier series we get

$$x^*(t) = \frac{1}{2\pi} \int_{-\infty}^{\infty} X^*(j\omega)e^{-j\omega t} d\omega.$$

Hence,

$$E = \int_{-\infty}^{\infty} x(t) \left[\frac{1}{2\pi} \int_{-\infty}^{\infty} X^*(j\omega)e^{-j\omega t} d\omega \right] dt$$

Now interchanging the order of the integrations, we get

$$\begin{aligned} E &= \frac{1}{2\pi} \int_{-\infty}^{\infty} X^*(j\omega) \left[\int_{-\infty}^{\infty} x(t)e^{-j\omega t} dt \right] d\omega = \frac{1}{2\pi} \int_{-\infty}^{\infty} X^*(j\omega)X(j\omega)d\omega \\ &= \frac{1}{2\pi} \int_{-\infty}^{\infty} |X(j\omega)|^2 d\omega. \end{aligned}$$

Thus, the energy in the time-domain representation of the signal is equal to the energy in the frequency-domain representation normalized by 2π .

Q.125 Compute the magnitude and phase of the frequency response of the first order discrete time LTI system given by equation (10)

$$y(n) - Ay(n-1) = Bx(n) \quad \text{where } |A| < 1.$$

Ans: $y(n) = Ay(n-1) + Bx(n)$

$$h(n) = BA^n u(n)$$

$$H(e^{j\omega}) = \sum_{n=-\infty}^{\infty} h(n)e^{-j\omega n} = \frac{B}{1 - Ae^{-j\omega}}$$

Since

$$1 - Ae^{-j\omega} = (1 - A \cos \omega) + jA \sin \omega$$

$$|1 - Ae^{-j\omega}| = \sqrt{(1 - A \cos \omega)^2 + (A \sin \omega)^2} = \sqrt{1 + A^2 - 2A \cos \omega}$$

$$\text{Angle } (1 - Ae^{-j\omega}) = \tan^{-1} \frac{A \sin \omega}{1 - A \cos \omega}$$

$$\therefore |H(e^{j\omega})| = \frac{|B|}{\sqrt{1 + A^2 - 2A \cos \omega}}$$

and

$$\text{angle } H(e^{j\omega}) = \text{Angle} \left[B - \tan^{-1} \frac{A \sin \omega}{1 - A \cos \omega} \right].$$

Q.126 Determine the Fourier transform of unit step $x(t) = u(t)$. (6)

Ans:

Fourier transform of $x(t)$ is $X(\omega) = \int_{-\infty}^{\infty} x(t)e^{-j\omega t} dt$

Thus Fourier transform of $u(t)$ is

$$X(\omega) = \int_{-\infty}^{\infty} u(t)e^{-j\omega t} dt = \int_0^{\infty} e^{-j\omega t} dt = \frac{1}{j\omega}.$$

Q.127 By using convolution theorem determine the inverse Laplace transform of the following functions. (8)

(i) $\frac{1}{s^2(s^2 - a^2)}$ (ii) $\frac{1}{s^2(s+1)}$

Ans:

(i) $F(s) = \frac{1}{s^2(s^2 - a^2)} = F_1(s)F_2(s)$

where $F_1(s) = \frac{1}{s^2}$ and $F_2(s) = \frac{1}{s^2 - a^2}$

Thus $f_1(t) = t$ and $f_2(t) = \frac{1}{a} \sinh(at)$

Now
$$\begin{aligned} \mathcal{L}^{-1} F(s) &= \int_0^t f_1(t-\tau)f_2(\tau)d\tau \\ &= \int_0^t (t-\tau) \frac{1}{a} \sinh(a\tau)d\tau \\ &= \frac{1}{a^3} [\sinh at - 1] \end{aligned}$$

(ii) $F(s) = \frac{1}{s^2(s+1)} = F_1(s)F_2(s)$

where $F_1(s) = \frac{1}{s^2}$ and $F_2(s) = \frac{1}{(s+1)}$

Thus $f_1(t) = t$ and $f_2(t) = e^{-t}$

Now
$$\begin{aligned} \mathcal{L}^{-1} F(s) &= \int_0^t f_1(t-\tau)f_2(\tau)d\tau \\ &= \int_0^t (t-\tau)e^{-\tau}d\tau = \int_0^t te^{-\tau}d\tau - \int_0^t \tau e^{-\tau}d\tau = (-te^{-t} + t) + (te^{-t} + e^{-t} - 1) = t + e^{-t} - 1 \end{aligned}$$

Q.128 Check the stability & causality of a continuous LTI system described as

$$H(s) = \frac{(s-2)}{(s+2)(s-3)} \quad (8)$$

Ans:

Given
$$H(s) = \frac{s-2}{(s+2)(s-3)} = \frac{1}{5} \left[\frac{4}{s+2} + \frac{1}{s-3} \right].$$

The system has poles at $s = -2, s = 3$.

Thus, the response of the system will be

$$h_1(t) = \frac{4}{5}e^{-2t}u(t) + \frac{1}{5}e^{3t}u(t), \quad \sigma > 3$$

$$h_2(t) = \frac{4}{5}e^{-2t}u(t) - \frac{1}{5}e^{3t}u(-t), \quad -2 < \sigma < 3$$

$$h_3(t) = -\frac{4}{5}e^{-2t}u(-t) - \frac{1}{5}e^{3t}u(-t), \quad \sigma < -2$$

Note that the response $h_1(t)$ is unstable and causal, $h_2(t)$ is stable and non-causal, $h_3(t)$ is stable and non-causal. Thus, the system cannot be both stable and causal simultaneously.

Q.129 Find the z -Transform $X(z)$ and sketch the pole-zero with the ROC for each of the following sequences. (8)

(i) $x(n) = \left(\frac{1}{2}\right)^n u(n) + \left(\frac{1}{3}\right)^n u(n)$

(ii) $x(n) = \left(\frac{1}{3}\right)^n u(n) + \left(\frac{1}{2}\right)^n u(-n-1)$

Ans:

(i) $x(n) = \left(\frac{1}{2}\right)^n u(n) + \left(\frac{1}{3}\right)^n u(n)$

$$\left(\frac{1}{2}\right)^n u(n) \leftrightarrow \frac{z}{z - \frac{1}{2}}, \quad |z| > \frac{1}{2}$$

$$\left(\frac{1}{3}\right)^n u(n) \leftrightarrow \frac{z}{z - \frac{1}{3}}, \quad |z| > \frac{1}{3}$$

Thus,
$$X(z) = \frac{z}{z - \frac{1}{2}} + \frac{z}{z - \frac{1}{3}} = \frac{2z\left(z - \frac{5}{12}\right)}{\left(z - \frac{1}{2}\right)\left(z - \frac{1}{3}\right)}, \quad |z| > \frac{1}{2}$$

(ii) $x(n) = \left(\frac{1}{3}\right)^n u(n) + \left(\frac{1}{2}\right)^n u(-n-1)$

$$\left(\frac{1}{3}\right)^n u(n) \leftrightarrow \frac{z}{z - \frac{1}{3}}, \quad |z| > \frac{1}{3}$$

$$\left(\frac{1}{2}\right)^n u(-n-1) \leftrightarrow -\frac{z}{z - \frac{1}{2}}, \quad |z| < \frac{1}{2}$$

$$\therefore X(z) = \frac{z}{z - \frac{1}{3}} - \frac{z}{z - \frac{1}{2}} = -\frac{1}{6} \frac{z}{\left(z - \frac{1}{2}\right)\left(z - \frac{1}{3}\right)}, \quad \frac{1}{3} < |z| < \frac{1}{2}$$

Q.130 Determine the inverse z transform of $x(z) = \frac{z}{3z^2 - 4z + 1}$ if the regions of

convergence are (i) $|z| > 1$, (ii) $|z| < \frac{1}{3}$, (iii) $\frac{1}{3} < |z| < 1$, (8)

Ans:

$$F(z) = \frac{X(z)}{z} = \frac{1}{3z^2 - 4z + 1} = \frac{1}{2} \left[\frac{z}{z-1} - \frac{z}{z-\frac{1}{3}} \right]$$

(i) ROC is $|z| > 1$

$$\therefore x(n) = \frac{1}{2} \left[(1)^n u(n) - \left(\frac{1}{3}\right)^n u(n) \right] = \frac{1}{2} \left[1 - \left(\frac{1}{3}\right)^n \right] u(n)$$

(ii) ROC is $|z| < \frac{1}{3}$

$$\therefore x(n) = \frac{1}{2} \left[-(1)^n + \left(\frac{1}{3}\right)^n \right] u(-n-1)$$

(iii) ROC is $\frac{1}{3} < |z| < 1$

$$\therefore x(n) = \frac{1}{2} \left[-(1)^n u(-n-1) - \left(\frac{1}{3}\right)^n u(n) \right] = -\frac{1}{2} \left[u(-n-1) + \left(\frac{1}{3}\right)^n u(n) \right]$$

Q.131 Consider the probability density function $f_X(x) = ae^{-b|x|}$, where X is a random variable whose allowable value range from $x = -\infty$ to $x = +\infty$. Find

(i) Cumulative distribution function $F_X(x)$.

(ii) Relationship between a and b .

(iii) $P[1 \leq X \leq 2]$ [assume $b = 6$] (8)

Determine mean, mean square and Variance.

Ans:

(i)

$$f_x(x) = ae^{-b|x|}$$

$$f_x(x) = \begin{cases} f_1(x) = ae^{bx}, & -\infty < x < 0 \\ f_2(x) = ae^{-bx}, & 0 < x < \infty \end{cases}$$

$$\therefore F_{x1}(x) = \int_{-\infty}^x ae^{bx} dx = \frac{a}{b} e^{bx}, x < 0$$

$$F_{x2}(x) = \int_0^x ae^{-bx} dx = \frac{a}{b} (1 - e^{-bx}), x > 0$$

Thus,

$$F_x(x) = \begin{cases} \frac{a}{b} e^{bx}, & x < 0 \\ \frac{a}{b} (1 - e^{-bx}), & x > 0 \end{cases}$$

(ii) Now

$$\int_{-\infty}^0 ae^{bx} dx + \int_0^{\infty} ae^{-bx} dx = 1$$

$$\rightarrow \frac{a}{b} + \frac{a}{b} = 1 \rightarrow 2a = b = 6 \text{ (given)} \rightarrow a = 3$$

(iii)

$$P[1 \leq X \leq 2] = \int_1^2 3e^{-6x} dx = 0.5e^6 [e^{-6} - 1].$$

Now

$$f_x(x) = \begin{cases} 3e^{6x} & x < 0 \\ 3e^{-6x} & x > 0 \end{cases}$$

$$\text{Mean} = E(x) = \int_{-\infty}^0 x3e^{6x} dx + \int_0^{\infty} x3e^{-6x} dx = 0$$

$$\text{Variance of } X = \sigma^2 = E(x^2) - [E(x)]^2 = 3 \left[\int_{-\infty}^0 x^2 e^{6x} dx + \int_0^{\infty} x^2 e^{-6x} dx \right] - 0 = \frac{1}{18}$$

Q.132 Find the power spectral density for the cosine signal $x(t) = 8\cos[2\pi(3)t + \pi/3]$ and also compute power in the signal. (8)

Ans:

Autocorrelation function of $x(t)$

$$\begin{aligned} R(\lambda) &= \lim_{T \rightarrow \infty} \frac{1}{T} \int_{-T/2}^{T/2} x(t)x(t+\lambda) dt \\ &= \lim_{T \rightarrow \infty} \frac{1}{T} \int_{-\pi/2}^{\pi/2} 8\cos(6\pi t + \pi/3) 8\cos[6\pi(t+\lambda) + \pi/3] dt \\ &= \lim_{T \rightarrow \infty} \frac{32}{T} \int_{-T/2}^{T/2} [\cos(12\pi t + 6\pi\lambda + 2\pi/3) + \cos 6\pi\lambda] dt \\ &= 0 + 32 \cos 6\pi\lambda = 32 \cos 6\pi\lambda \end{aligned}$$

$$\text{PSD} = F[R(\lambda)] = F[32 \cos 6\pi\lambda] = 32\pi[\delta(\omega - 2\pi) + \delta(\omega + 6\pi)]$$

$$\text{Power in the signal is } R(0) = 32 \cos 6\pi\lambda \Big|_{\lambda=0} = 32 \text{ W}$$