

Code: D-05  
Time: 3 Hours

Subject: ELECTRICAL ENGINEERING  
Max. Marks: 100

JUNE-2003

NOTE: There are 11 Questions in all.

- Question 1 is compulsory and carries 16 marks. Answer to Q. 1. must be written in the space provided for it in the answer book supplied and nowhere else.
- Answer any THREE Questions each from Part I and Part II. Each of these questions carries 14 marks.
- Any required data not explicitly given, may be suitably assumed and stated.

---

**Q.1 Choose the correct or best alternative in the following:** (2x8)

- a. Kirchoff's current law is applicable to only
- (A) Closed loops in a network.      (B) Junctions in a network.  
(C) Electronic circuits.              (D) Electric circuits.
- b. The capacity of a cell is measured in
- (A) Watt-hours.                          (B) Watts.  
(C) Amperes.                              (D) Ampere-hours.
- c. The dynamic impedance of an R-L and C parallel circuit at resonance is \_\_\_\_\_.
- (A) C/LR                                      (B) L/CR  
(C) LC/R                                      (D) R/LC
- d. The power factor of an a.c. circuit is equal to
- (A) Cosine of the phase angle.      (B) Sine of the phase angle.  
(C) Unity for a reactive circuit.      (D) Infinity for a resistive circuit.
- e. If the line current in a delta connected system is  $I_L$ , then phase current will be equal to
- (A)  $I_L$ .                                      (B)  $I_L/\sqrt{3}$ .  
(C)  $\sqrt{3}/I_L$ .                              (D)  $I_L/\sqrt{2}$ .
- f. Fleming's left hand rule is applicable to
- (A) DC generators.                      (B) DC motors.  
(C) Alternator.                            (D) Transformer.

- g. A three-point starter is considered suitable for dc
- (A) Series motors                      (B) Shunt motors  
(C) Compound motors                (D) Shunt as well as compound motors
- h. The two windings of a transformer are
- (A) conductively linked.              (B) inductively linked.  
(C) not linked at all.                 (D) electrically linked.

**PART I**

**Answer any THREE Questions. Each question carries 14 marks.**

- Q.2** a. Explain maximum power Transfer theorem. (4)
- b. With reference to the network of figure given below, by applying Thevenin's theorem find the following:
- (i) The equivalent e.m.f. of the network when viewed from terminals A and B.
- (ii) The equivalent resistance of the network when looked into from terminals A and B.
- (iii) Current in the load resistance  $R_L$  of  $15\Omega$ . (10)

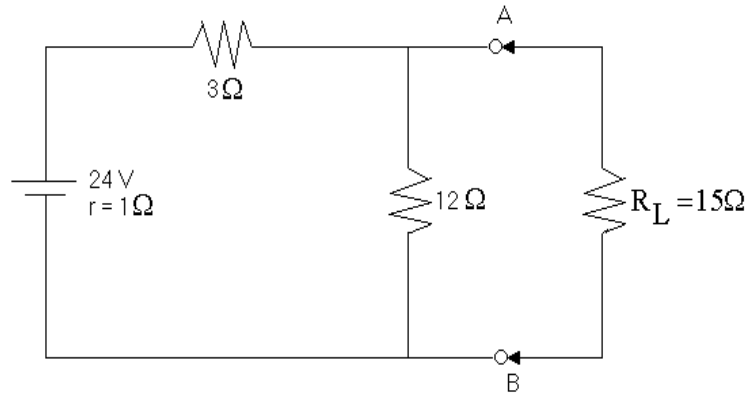

- Q.3** a. What are the advantages and disadvantages of three-phase system over single-phase system? (8)
- b. A 3-phase, 400 V supply is connected to a 3-phase star-connected balanced load. The line current is 20A, and the power consumed by the load is 12kW. Calculate the impedance of the load, phase current and power factor. (6)

- Q.4** a. Give the construction of core and shell type transformers. (10)
- b. The secondary induced e.m.f. in a transformer is 250 V. Its terminal voltage is 230 V when supplying rated current of 50 A at 0.8 pf lagging. Determine its percentage voltage regulation. (4)
- Q.5** A pure resistance of 50 ohms is in series with a pure capacitance of  $100\mu\text{F}$ . The series combination is connected across 100 V, 50 Hz supply. Find :
- (i) The impedance
  - (ii) Current
  - (iii) Power factor
  - (iv) Phase angle
  - (v) Voltage across resistor
  - (vi) Voltage across capacitor (14)
- Q.6** A resistance of  $20\ \Omega$ , an inductance of 0.2 H and a capacitance of  $100\mu\text{F}$  are connected in series across 220 V, 50 Hz mains. Determine the following:
- (i) Impedance
  - (ii) Current
  - (iii) Voltage across R, L and C
  - (iv) Power
  - (v) Power factor. (14)

---

**PART II**

**Answer any THREE Questions. Each question carries 14 marks.**

---

- Q.7** What are the disadvantages and causes of a low power factor? What steps should be taken to improve the power factor? (14)
- Q.8** a. Explain the principle of operation of any one type of d.c motor. (8)
- b. A 440 Volt D C Shunt Motor has an armature resistance of  $0.8\ \Omega$  and field resistance of  $200\ \Omega$ . Determine the back e.m.f. when giving an output of 7.46 kW at 85 percent efficiency. (6)
- Q.9** a. Explain the construction of 3-phase induction motors. Also draw the torque speed characteristics. (10)
- b. A 3-phase induction motor is wound for 4-poles and is supplied from 50 Hz system. Calculate
- (i) The synchronous speed
  - (ii) The speed of the motor when the slip is 4%. (4)

**Q.10** Give the comparison of steam power plant, hydroelectric plant, diesel power plant and nuclear power plant on the basis of operating cost, initial cost, efficiency, maintenance cost and availability of source of power. **(14)**

**Q.11** Write notes on

- (i) Chemical changes during discharging and charging of cell.
- (ii) Necessity of a starter for d.c motors.
- (iii) Selection of motors for specific engineering application. **(14)**

Code: D-05  
Time: 3 Hours

Subject: ELECTRICAL ENGINEERING  
Max. Marks: 100

December 2003

NOTE: There are 11 Questions in all.

- Question 1 is compulsory and carries 16 marks. Answer to Q. 1. must be written in the space provided for it in the answer book supplied and nowhere else.
  - Answer any THREE Questions each from Part I and Part II. Each of these questions carries 14 marks.
  - Any required data not explicitly given, may be suitably assumed and stated.
- 

**Q.1 Choose the correct or best alternative in the following: (2x8)**

- a. The nodal analysis is primarily based on the application of \_\_\_\_\_.
- (A) KVL (B) KCL  
(C) Ohms laws (D) both Ohms law & KCL
- b. The resonance curve for a series circuit is a plot of frequency versus \_\_\_\_\_.
- (A) voltage (B) impedance  
(C) current (D) reactance
- c. An induction motor employs a starting device to restrict \_\_\_\_\_ at start.
- (A) line voltage (B) line current  
(C) torque (D) power
- d. A capacitor-start capacitor-run induction motor is basically a \_\_\_\_\_ motor.
- (A) two-phase (B) ac series  
(D) commutator (D) synchronous
- e. The transformation ratio of a transformer is \_\_\_\_\_.
- (A)  $I_2/I_1$  (B)  $E_1/E_2$  .  
(C)  $N_2/N_1$  . (D)  $N_1/N_2$  .
- f. The yoke of a small dc machine is made of \_\_\_\_\_.
- (A) copper. (B) aluminium.  
(C) cast iron. (D) stainless steel.



- Q.5** Find the value of power developed in each arm of the series-parallel circuit shown in Fig.2 given below:

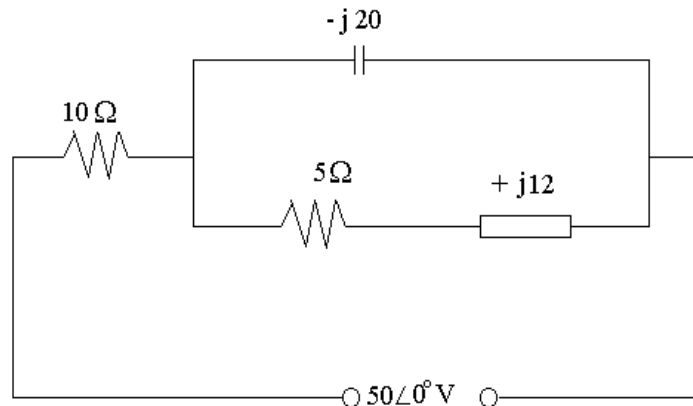

Fig.2

(14)

- Q.6** A resistance  $R$ , an inductance  $L=0.01$  H and a capacitance  $C$  are connected in series. When a voltage  $v= 400 \cos (300t-10^\circ)$  volts is applied to the series combination, the current flowing is  $10\sqrt{2} \cos (300t-55^\circ)$  amperes, Find  $R$  and  $C$ . (14)

---

**PART II**

Answer any **THREE** Questions. Each question carries **14** marks.

---

- Q.7** a. What are the functions of commutator in a DC machine? (4)  
 b. Derive the equation of the EMF induced in a DC machine. (10)
- Q.8** a. Give the comparison of the two types of induction motors. (5)  
 b. A 3-phase induction motor is wound for 4-poles and is supplied from 50 Hz system. Calculate  
 (i) Synchronous speed  
 (ii) The motor speed when the slip is 4 %  
 (iii) The motor frequency when it runs at 600 r.p.m. (9)
- Q.9** a. Explain the working of a capacitor start single-phase motor. (7)  
 b. Draw the circuit diagram of capacitor-start-capacitor-run single-phase induction motor. Explain the function of the second capacitor in it. (7)
- Q.10** a. What are the disadvantages of low power factor? How can it be improved? (8)  
 b. What are the advantages of high voltage transmission? (6)
- Q.11** Write notes on  
 (i) Solar cells.  
 (ii) Construction and chemical equations during charge and discharge of lead acid battery. (7+7)

Code: D-05  
Time: 3 Hours



Subject: ELECTRICAL ENGINEERING  
Max. Marks: 100

NOTE: There are 11 Questions in all.

- Question 1 is compulsory and carries 16 marks. Answer to Q. 1. must be written in the space provided for it in the answer book supplied and nowhere else.
- Answer any THREE Questions each from Part I and Part II. Each of these questions carries 14 marks.
- Any required data not explicitly given, may be suitably assumed and stated.

**Q.1 Choose the correct or best alternative in the following: (2x8)**

- a. Transformer for constant voltage applications should have \_\_\_\_\_regulation
- (A) high (B) zero  
(C) low (D) good
- b. The reactance offered by a capacitor to alternating current of frequency 50 Hz is  $10\Omega$ . If the frequency is increased to 100 Hz reactance becomes \_\_\_\_\_ ohms.
- (A) 20 (B) 5  
(C) 2.5 (D) 40
- c. When phase sequence of 3 phase load is reversed
- (A) phase powers are changed.  
(B) phase currents are changed.  
(C) phase currents change in angle but not in magnitude.  
(B) total power consumed is changed.
- d. For ceiling fans generally the single phase motor used is
- (A) split phase type. (B) capacitor start type.  
(C) Capacitor start and run type. (D) permanent capacitor type.
- e. The rotating part of dc machine is called the
- (A) rotor (B) field.  
(C) armature. (D) stator.
- f. When  $\omega L$  is equal to  $\frac{1}{\omega c}$  then net reactance is
- (A) maximum. (B) half.  
(C) zero. (D) equal to resistance.

- g. One kilo-watt-hour (1 kWh) is equal to
- (A)  $36 \times 10^5$  Joules.                      (B)  $36 \times 10^4$  Joules.  
(C)  $36 \times 10^3$  Joules.                      (D)  $36 \times 10^6$  Joules.
- h. The basic function of a transformer is to change the level of
- (A) voltage                                      (B) power  
(C) frequency                                  (D) power factor

---

**PART I**

**Answer any THREE Questions. Each question carries 14 marks.**

---

- Q.2** a. Define
- (i) Passive network.                      (ii) Active network.  
(iii) Linear circuit.                      (iv) Non-linear circuit.                      (8)
- b. State Norton's and Thevenin's theorem.                      (6)
- Q.3** a. Explain the construction of core and shell type of transformers.                      (6)
- b. A single-phase 50 Hz transformer has 80 turns on the primary winding and 280 turns on the secondary winding. The voltage applied across the primary winding is 240 V at 50 Hz. Calculate
- (i) the maximum flux density in the core  
(ii) induced emf in the secondary. The cross-sectional area of the core is  $200 \text{ cm}^2$ .                      (8)
- Q.4** a. What are the advantages and disadvantages of three-phase systems over single-phase system?                      (8)
- b. A star connected 3-phase load has a resistance of 6 ohms and an inductive reactance of 8 ohms in each branch. A line-to-line voltage of 220 V is impressed through a 3-phase auto-transformer. Find the voltage across each branch, line voltages and line currents and total active power.                      (6)
- Q.5** Define power factor in an a.c. circuit. A 0.8 pf (lagging) load draws 100 A from a 250 V, single-phase ac supply mains. Find
- (ii) the value of the true power and apparent power.  
(iii) The value of the circuit components.                      (14)
- Q.6** A circuit has a resistance of R ohms and an inductance of L Henry connected in series. If it is connected to a 240 V, 50 Hz supply mains it consumes 300 watts and the voltage drop across R is 100 V. Calculate the value of inductance L.                      (14)

---

**PART II**

**Answer any THREE Questions. Each question carries 14 marks.**

---

- Q.7** a. Explain the parts of a DC machine? **(10)**
- b. A 6-pole lap wound dc generator has an armature with 90 slots and 6 conductors per slot and rotates at 1200 rpm. The flux per pole is 50 m Wb. Calculate the emf generated. **(4)**
- Q.8** a. Explain the construction of 3-phase induction motor. **(8)**
- b. What is meant by slip of an induction motor? **(6)**
- Q.9** Explain the working principle and application of single-phase induction motors. Are single phase induction motors self-starting? Justify this statement. **(14)**
- Q.10** What are the advantages and disadvantages of D.C. and A.C. Transmission of power? **(14)**
- Q.11** Write notes on
- (i) Generation of electrical energy.
- (ii) Different methods of charging a battery. **(7+7)**

Code: D-05  
Time: 3 Hours

Subject: ELECTRICAL ENGINEERING  
Max. Marks: 100

DECEMBER-2004

NOTE: There are 11 Questions in all.

- Question 1 is compulsory and carries 16 marks. Answer to Q. 1. must be written in the space provided for it in the answer book supplied and nowhere else.
- Answer any THREE Questions each from Part I and Part II. Each of these questions carries 14 marks.
- Any required data not explicitly given, may be suitably assumed and stated.

Q.1 Choose the correct or best alternative in the following: (2x8)

- a. A series RLC circuit will have unity power factor if operated at a frequency of \_\_\_\_\_.
- (A)  $\frac{1}{LC}$ . (B)  $\frac{1}{\omega\sqrt{LC}}$ .  
(C)  $\frac{1}{\omega^2LC}$ . (D)  $\frac{1}{2\pi\sqrt{LC}}$ .
- b. The difference between synchronous speed and the actual speed of an induction motor is known as \_\_\_\_\_.
- (A) regulation. (B) back lash.  
(C) slip. (D) lag.
- c. The efficiency of a transformer is given as \_\_\_\_\_.
- (A) output/(output + losses). (B) (output + losses)/output.  
(C) input/output. (D) (output + losses)/input.
- d. Speed of a motor is given by \_\_\_\_\_.
- (A) 120 f/p. (B) 120 p/f.  
(C) 60f/p. (D) 60 p/f.
- e. Load factor is defined as \_\_\_\_\_.
- (A) average demand / maximum demand.  
(B) average demand / installed capacity.  
(C) maximum demand / average demand.  
(D) maximum demand / installed capacity.
- f. Like a resonant R-L-C circuit, a parallel resonance circuit also \_\_\_\_\_.
- (A) has a power factor of unity. (B) offers minimum impedance.  
(C) draws maximum current. (D) magnifies current.

- g. Slip rings for an induction motors are made of
- (A) Aluminium. (B) Carbon.  
 (C) Phosphor bronze. (D) Cobalt steel.
- h. The motor which has the least noise is the \_\_\_\_\_.
- (A) capacitor motor. (B) universal motor.  
 (C) shaded pole motor. (D) hysteresis motor.

**PART I**

**Answer any THREE Questions. Each question carries 14 marks.**

- Q.2** a. Define the following terms:-
- (i) Node. (ii) Path. (iii) Branch. (iv) Loop. (1½×4)
- b. Apply Kirchoff's voltage law, to find the values of current  $i$  and the voltages  $V_1$  and  $V_2$  in the circuit of the Fig.1 given below, which contains a current – dependent voltage source. What is the voltage of the dependent source? All resistance values are in ohms. (8)

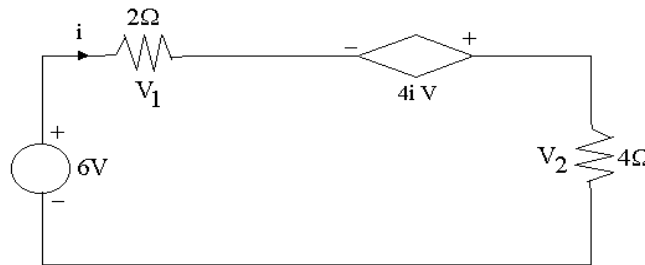

Fig.1

- Q.3** a. Derive the value of equivalent resistance in both series and parallel combinations separately. (8)
- b. Convert the given delta network (in Fig.2) into its equivalent star network. (6)

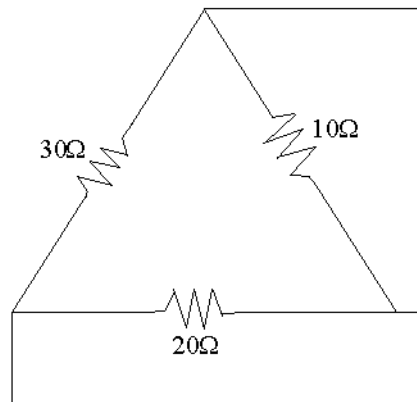
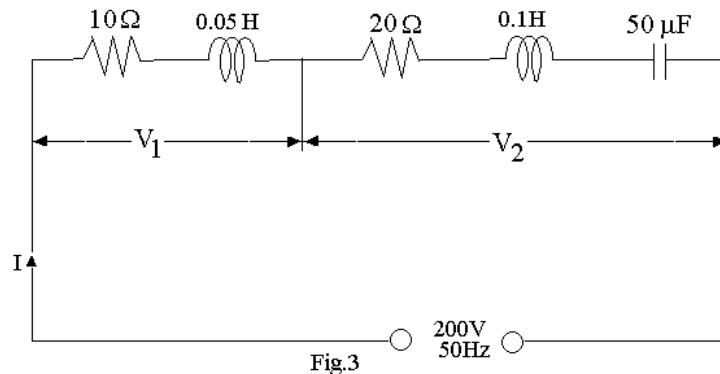

Fig.2

- Q.4** a. What is meant by commutation? (3)
- b. Define voltage regulation of a transformer. (3)
- c. For the circuit shown in the Fig.3 below, find the values of  
 (iv) current  
 (v)  $V_1$  and  $V_2$   
 (vi) p.f. (8)



- Q.5** a. With a circuit diagram explain the open circuit test of a transformer. (8)
- b. A single-phase 50 KVA transformer has a primary voltage of 6,600 V and a secondary voltage of 254 V; also it has 32 secondary turns. Calculate the number of primary turns; also primary and secondary currents. (6)
- Q.6** a. Draw the speed-torque characteristics of various types of dc motors. (6)
- b. A dc shunt motor rated 50 kW connected to a 250 V supply is loaded and draws a current of 200A when running at a speed of 1250 rpm. Given  $R_a = 0.22$  ohms :  
 (i) determine the load torque if the rotational loss (including iron loss) is 600W.  
 (ii) determine the motor efficiency if the shunt field resistance is 125 ohms. (8)

---

**PART II**

**Answer any THREE Questions. Each question carries 14 marks.**

---

- Q.7** a. Compare the features of shunt and series motors. (8)
- b. A 400V, 3-phase, 6-pole induction motor draws a line current of 80A at 0.75 pf at 4% slip. Its efficiency is 85%. Calculate the shaft output and shaft torque. (6)
- Q.8** Explain the construction, working and application of a shaded pole motor. (14)
- Q.9** a. What are the advantages and disadvantages of HVDC systems? (8)
- b. The maximum demand on a power station is 100 MW. If the annual load factor is 40%, calculate the energy generated in a year. (6)

**Q.10** a. With the help of a diagram explain the basic structure of a PV cell. (6)

b. A diesel station supplies the following loads to various consumers:

Industrial consumers = 1500 kW      Commercial establishment = 750 kW

Domestic power = 100 kW      Domestic lighting = 450 kW.

If the maximum demand on the station is 2500 kW and the number of kWh generated per year is  $45 \times 10^5$ , determine

(i) the diversity factor and      (ii) annual load factor. (8)

**Q.11** Write notes on:

(i) Selection of motors for different engineering applications.

(ii) Low power factor and its improvement. (7+7)