

AMIETE – ET (OLD SCHEME)

Time: 3 Hours

JUNE 2012

Max. Marks: 100

PLEASE WRITE YOUR ROLL NO. AT THE SPACE PROVIDED ON EACH PAGE IMMEDIATELY AFTER RECEIVING THE QUESTION PAPER.

NOTE: There are 9 Questions in all.

- Question 1 is compulsory and carries 20 marks. Answer to Q.1 must be written in the space provided for it in the answer book supplied and nowhere else.
- The answer sheet for the Q.1 will be collected by the invigilator after 45 minutes of the commencement of the examination.
- Out of the remaining EIGHT Questions answer any FIVE Questions. Each question carries 16 marks.
- Any required data not explicitly given, may be suitably assumed and stated.

Q.1 Choose the correct or the best alternative in the following: (2×10)

- a. Bandwidth of MSK is _____ that of QPSK.
- | | |
|-----------------|---------------------------|
| (A) Higher than | (B) Lower than |
| (C) Equal to | (D) Less than or equal to |
- b. Which of the following modulation schemes provides 4 bits per baud?
- | | |
|------------|------------|
| (A) QPSK | (B) 8-PSK |
| (C) 16-QAM | (D) 64-QAM |
- c. Hamming weight $w(S_i)$ of a code S_i is defined as the
- | | |
|---|---|
| (A) No. of 0's in codeword S_i | (B) No. of 1's in codeword S_i |
| (C) No. of 1's in even locations of S_i | (D) No. of 0's in even locations of S_i |
- d. In the eye pattern, as eye closes,
- | | |
|-----------------------------|-----------------------------|
| (A) ISI increases | (B) ISI decreases |
| (C) Timing Jitter increases | (D) Timing Jitter decreases |
- e. The CRC circuit is basically
- | | |
|----------------------------|-------------------------|
| (A) Decoder circuit | (B) Multiplexer circuit |
| (C) Shift Register circuit | (D) Adder circuit |
- f. In a PCM system, the amplitude levels are transmitted in a 7 unit code. The sampling is done at rate of 10 kHz. The bandwidth should be
- | | |
|------------|------------|
| (A) 5 kHz | (B) 35 kHz |
| (C) 70 kHz | (D) 5 MHz |

- g. CDMA technique is not used in satellite communication because of
- (A) wastage of bandwidth (B) wastage of power
(C) increase in delay (D) complexity of operation
- h. Which encoding method uses alternating positive and negative values for 1s?
- (A) NRZ-I (B) RZ
(C) Manchester (D) AMI
- i. The use of non-uniform quantization levels leads to
- (A) Reduction in transmission bandwidth
(B) Increase in maximum SNR
(C) Increase in SNR for low level signals
(D) Simplification of quantization process
- j. In Fast Frequency Hopping (FFH)
- (A) Hopping rate is equal to or greater than the bit rate of baseband signal.
(B) Hopping rate is equal to or less than the bit rate of baseband signal.
(C) The desired privacy and interference protection is less.
(D) None of the above.

**Answer any FIVE Questions out of EIGHT Questions.
Each question carries 16 marks.**

- Q.2** a. Explain the following terms:
- (i) Aliasing.
(ii) SNR bandwidth trade off. (8)
- b. The signal $f(t) = 10 \cos(20\pi t) \cos 200\pi t$ is sampled at a rate of 250 times/sec. Determine the spectrum of the resulting signal. What is the Nyquist rate? (8)
- Q.3** a. What is the basic difference between uniform and non uniform quantization? (8)
- b. Explain the operation and sketch the receiver of a differential PCM. (8)
- Q.4** Demodulation is recovery of waveform and detection is decision making process of selecting the digital meaning of that waveform. Explain it and show in a neatly labelled block diagram, the two basic steps involves in demodulation/detection of digital signals. What is equalizing filter? What is a matched filter? (16)
- Q.5** a. Explain the Non-Coherent detection of FSK. (8)

- b. Find the bit error probability for a BPSK system with a bit rate of 1Mbit/s. The received waveforms $s_1(t) = A \cos \omega_0 t$ and $s_2(t) = -A \cos \omega_0 t$ are coherently detected with a matched filter. The value of A is 10 mV. Assume that the single sided noise power spectral density is $N_0 = 10^{-11}$ W/Hz and signal power and energy per bit are normalized relative to a 1Ω load. (8)

- Q.6 a. In the case of orthogonal signalling such as MFSK, why does error performance improve with higher dimensional signalling? (8)

- b. Explain the principle behind Antijam capabilities of spread spectrum signal. (8)

- Q.7 a. Explain the following terms:
 (i) Hamming distance (2)
 (ii) Weight of a code (2)
 (iii) Hamming Bound (2)

- b. A (7, 4) linear block code is having parity check matrix H given by

$$H = \begin{bmatrix} 1 & 1 & 1 & 0 & 1 & 0 & 0 \\ 1 & 1 & 0 & 1 & 0 & 1 & 0 \\ 1 & 0 & 1 & 1 & 0 & 0 & 1 \end{bmatrix}$$

Code Word received in 1000011 for a transmitted code word C. Find the corresponding data transmitted. (10)

- Q.8 a. Explain decoding of a convolutional code using Viterbi decoding. What do you mean by hard decision and soft decision decoding? (10)

- b. Draw a state transition diagram for rate $\frac{1}{2}$ convolutional encoder as given in the figure below:- (6)

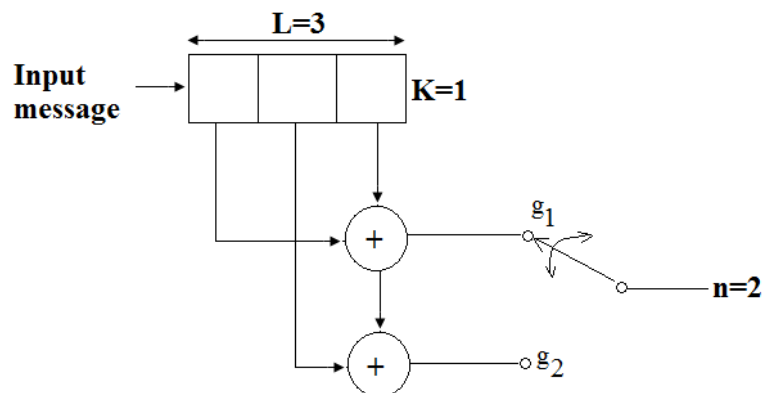

- Q.9 Explain short notes on any **TWO**:

- (i) Jamming considerations.
 (ii) Frequency Hopping Acquisition scheme.
 (iii) PN Auto Correlation function. (8+8)