

DiplETE – ET

Time: 3 Hours

DECEMBER 2012

Max. Marks: 100

PLEASE WRITE YOUR ROLL NO. AT THE SPACE PROVIDED ON EACH PAGE IMMEDIATELY AFTER RECEIVING THE QUESTION PAPER.

NOTE: There are 9 Questions in all.

- Question 1 is compulsory and carries 20 marks. Answer to Q.1 must be written in the space provided for it in the answer book supplied and nowhere else.
- The answer sheet for the Q.1 will be collected by the invigilator after 45 minutes of the commencement of the examination.
- Out of the remaining EIGHT Questions answer any FIVE Questions. Each question carries 16 marks.
- Any required data not explicitly given, may be suitably assumed and stated.

Q.1 Choose the correct or the best alternative in the following: (2×10)

a. The process used to produce a metal thin film layer that will serve to make interconnections of the various components on the chip is

- (A) Metallization (B) Dielectric Isolation
(C) Ion Implantation (D) Diffusion

b. Which of the following circuit is known as the emitter follower

- (A) CB amplifier (B) CC amplifier
(C) CE amplifier (D) CS amplifier

c. Which of the following amplifier suffer from the cross over distortion?

- (A) Class B amplifier (B) Class A amplifier
(C) Class AB amplifier (D) Class C amplifier

d. The typical value of forward voltage drop for an LED is

- (A) 0.7 Volts (B) 0.3 Volts
(C) 2.6 Volts (D) 1.2 Volts

e. The ideal value of slew rate for an op-amp is

- (A) Zero (B) Infinite
(C) Low (D) Medium

f. The output voltage in the circuit shown below is

- (A) 15 V (B) 10 V
(C) - 15 V (D) -10 V

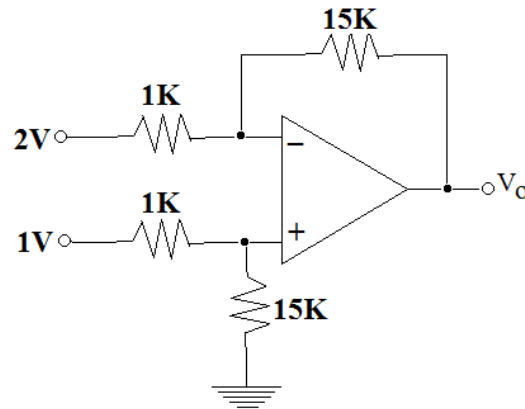

- g. The frequency of oscillation of a Wien Bridge Oscillator using op-amp with $R=10\text{ K Ohm}$ and $C=0.01\ \mu\text{F}$ is
- (A) 1674.46 Hz (B) 1592.35 Hz
(C) 1289.4 Hz (D) 1952 Hz
- h. The output frequency of an astable multivibrator using 555 timer IC is available at
- (A) Pin 3 (B) Pin 2
(C) Pin 4 (D) Pin 6
- i. For a FET $I_{DSS} = 16\text{ mA}$, $V_p = -8\text{V}$. The value of transconductance (g_m) for $V_{GS} = -4\text{V}$ is
- (A) $3500\ \mu\text{S}$ (B) $2500\ \mu\text{S}$
(C) $2000\ \mu\text{S}$ (D) $1500\ \mu\text{S}$
- j. The number of op-amps required for a 3 bit output simultaneous converter type ADC is
- (A) 7 (B) 5
(C) 3 (D) 15

Answer any FIVE Questions out of EIGHT Questions.
Each question carries 16 marks.

- Q.2** a. Explain any one of Basic Planar process used in IC fabrication. (8)
- b. Explain Enhancement type MOSFET fabrication process. (8)
- Q.3** a. Draw the h-parameter equivalent circuit of Common Collector Amplifier circuit and derive the expressions for input impedance, output impedance, voltage gain and current gain. (10)

- b. Calculate the input impedance, output impedance and voltage gain for the circuit shown below; $R_1=39\text{ K}\Omega$, $R_2=47\text{ K}\Omega$, $R_C=1.8\text{ K}\Omega$, $R_L=68\text{ K}\Omega$ and $h_{fe}=80$, $h_{oe}=1.5\text{ }\mu\text{S}$, $h_{ie}=1.2\text{ K}\Omega$. (6)

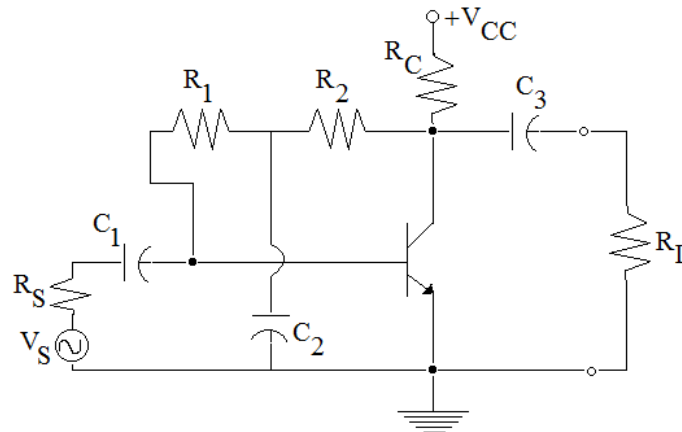

- Q.4** a. Explain with a neat diagram, the working of n-channel JFET. (8)
 b. For given IRF520

V_{DS} (max)	I_D (max)	P_D (max)	r_d (on)
100V	8A	40W	$0.3\text{ }\Omega$

g_{FS}	V_{GS} (Th)
1.5S(min)	2V(min)
2.9 S(typ)	4V(max)

Calculate the gate – source voltage required to produce a 7A drain current in an IRF520. Determine the drain source ON voltage and the device power dissipation at $I_D = 7\text{A}$. (8)

- Q.5** a. Explain with a diagram, the working of a Class B push pull power amplifier. (8)
 b. Explain the complementary Emitter Follower Circuit. (8)

- Q.6** a. Write the characteristics of an ideal op-amp. (4)
 b. Derive an expression for the gain of an Inverting Amplifier using op-amp. (5)
 c. Explain the term Slew Rate and obtain an expression for maximum frequency in terms of slew rate. (7)

- Q.7** a. Explain the working of a differentiator using an op-amp. (8)
 b. Explain the working of the following circuits using op-amp. (8)
 (i) Voltage to Current Converter
 (ii) Current to Voltage Converter

Code: DE56

Subject: ANALOG ELECTRONICS

- Q.8** a. Explain the working of monostable multivibrator using an op-amp. (8)
- b. Explain the working of an astable multivibrator using an op-amp and derive the expression for frequency of output wave. (8)
- Q.9** a. Explain the working of a Series Op-Amp Regulator. (7)
- b. Explain the working of Successive Approximation Type ADC. (9)